

FieldBlock™ Enclosure with:

DeviceNet Input/Output Module (FBM92____)

These I/O Modules are designed to function as DeviceNet nodes with termination points for connecting switches/sensors (discrete and analog), as well as outputs to operate devices such as low power solenoid valves and relays.

Inputs and Outputs

- Two (2) Discrete Inputs
- Two (2) Discrete Outputs
- One (1) Analog Input (4-20mA)

Features

- LED input displays for Inputs 1 & 2
- Pre-determined output fail state
- Cycle count
- Date of last service



(See Page 3 detailed wiring instructions)

FieldBlock Dimensions (in mm)

Front View

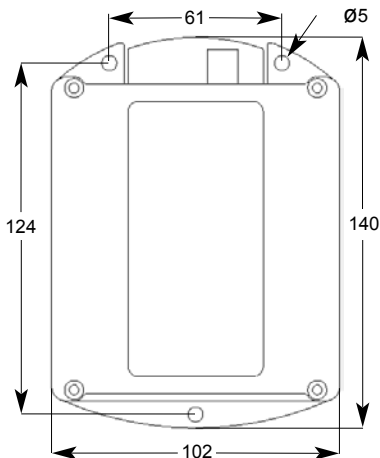

Side View

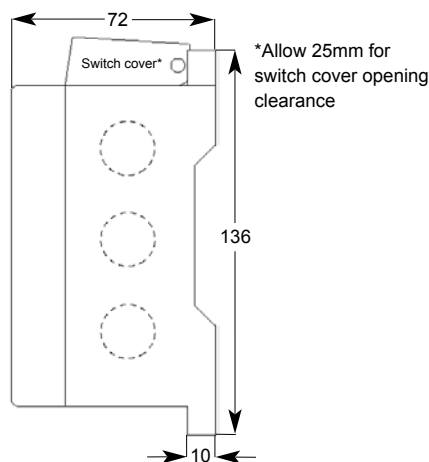

Top View

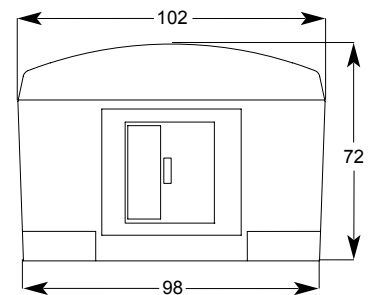

© 2001 StoneL Corporation

StoneL Corporation
One StoneL Dr
26275 US Hwy 59
Fergus Falls, MN 56537
USA

Telephone: 218.739.5774
Toll Free: 800.843.7866
Fax: 218.739.5776
E-mail: sales@stonel.com
Website: www.stonel.com

Example: FBM92002

| | <u>Function</u> | <u>Entry Options</u> |
|---------------|--|--|
| FB M92 | I/O Module (2 DI/2 DO/1 AI), DeviceNet | 002* (1) 4-Pin Male Micro-Connector, (5) 4-pin Female Micro-Connectors 007 (6) 1/2 NPT Conduit Entries 009 (6) M20 cable glands (.20 -.35 diameter cable) 017* (1) 4-Pin Male Mini-Connector, (5) 4-pin Female Micro-Connectors * See Page 4 for Connector pin-out |

General Specifications

| | | | |
|----------------------------------|----------------------|-----------------------------|---------------------------------|
| Operating Life | Unlimited | Temperature Range | -40° to +85° C (-23° to 185° F) |
| Materials of Construction | | Enclosure Protection | NEMA 4, 4X & 6; IP67 |
| Housing and Cover | Lexan® Polycarbonate | Warranty | |
| Elastomer Seals | Buna-N | Complete Assemblies | Two Years |
| Fasteners | Stainless Steel | | |

Lexan is a registered trademark of General Electric Corporation.

Mounting Instructions

Mounting The FieldBlock Enclosure

1. Locate the position where the FieldBlock enclosure will be mounted. Ensure that disconnect switch cover will have sufficient clearance to be lifted.
2. Attach the FieldBlock enclosure to a wall or other stationary flat surface using the mounting holes provided.

Attaching Cables and Connectors

1. Cable glands and connectors are provided for convenient wiring. Ensure all connections are securely tightened.
2. Follow all applicable NEC codes and other regulations.

Installing & Removing Cover

1. To insure NEMA 4, 4X and 6 ratings are maintained the cover **must be** completely closed and the gasket sealed to keep out water.
2. Tighten cover screws to 05-30 inch lbs.

DeviceNet 2 DI/2 DO/1 AI Input/Output Modules

| | | |
|--|--|---|
| <p>Operating Voltage 24 VDC via DeviceNet voltage</p> <p>Discrete Inputs (2) 7mA @ 24 VDC gold contact mechanical, low power reed, or 2 wire and 3 wire PNP solid state sensors</p> <p>Analog Input (1) Analog (4-20 mA) input. 8 bit resolution (0.4%)</p> <p>Outputs (2) 24 VDC - Bus Powered (4 Watts total power available)</p> <p>Current Usage 60mA (no I/O enabled)</p> <p>Default Address 63</p> | <p>Bit Assignment:</p> <p><u>Inputs: (3 Bytes)</u></p> <p>Bit 0 = Input 1 (Red)</p> <p>Bit 1 = Input 2 (Green)</p> <p>Bit 4 = Fault Bit (On if both Input 1 and Input 2 bits are set)</p> <p>Bits 8-15 = Analog Input (Low Byte)</p> <p>Bits 16-23 = Analog Input (High Byte)</p> <p>Operating Life Unlimited</p> <p>Warranty Two Years</p> | <p><u>Outputs (1 Byte)</u></p> <p>Bit 0 = Output 1</p> <p>Bit 1 = Output 2</p> |
|--|--|---|

Input/Output Module Wiring Diagram and Installation Notes

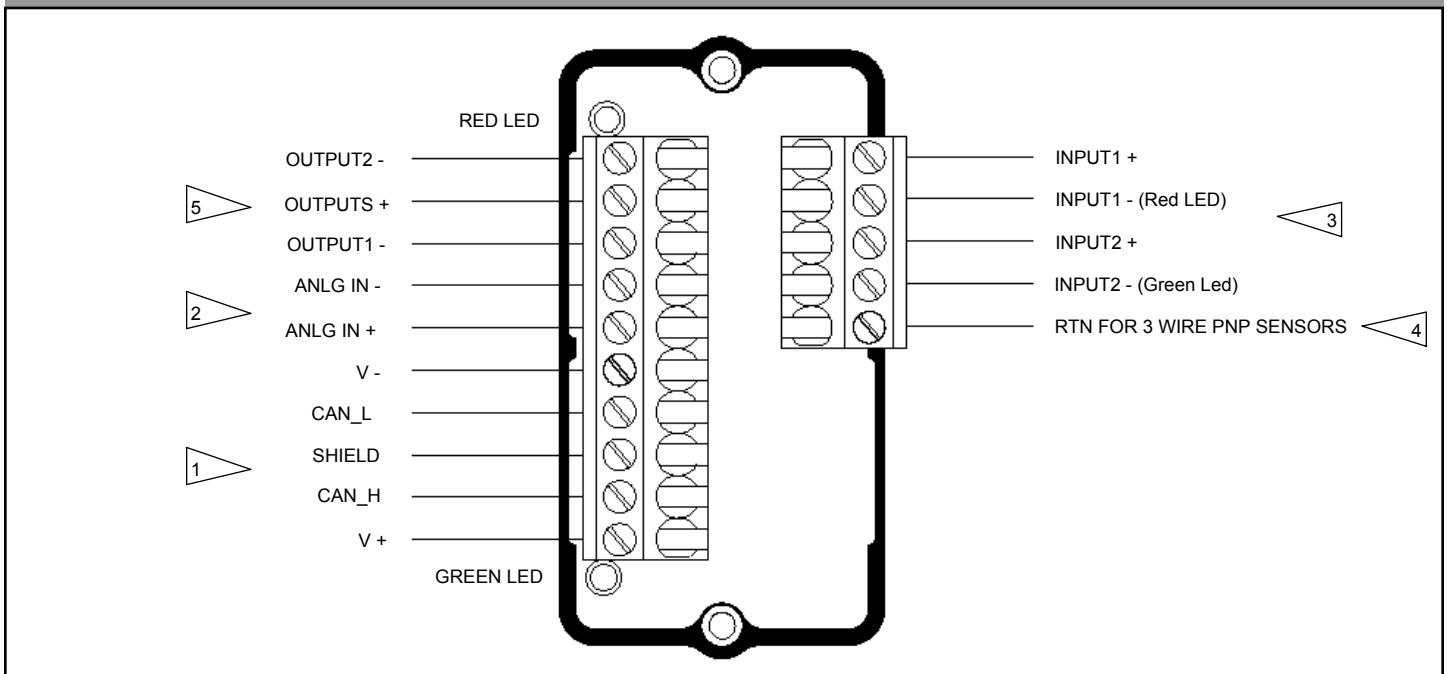

INSTALLATION NOTES:

1. DeviceNet bus communications connection points.
2. 24 VDC Bus powered Analog Input device connection points. (4-20mA)
3. Bus powered Discrete Input connection points for low power (7mA @ 24 VDC) gold contact mechanical switches, low power reed, or 2 wire and 3 wire PNP solid state proximity sensors (max allowable current leakage of sensors 0.165mA). Red LED is local indication of discrete Input 1 on/off status and the Green LED for discrete Input 2 on/off status.
4. Connection point for the "return" of 3 wire PNP sensors. (See Note 3)
5. Connection points for 24 VDC Bus powered Discrete Outputs (4 watts total power available) for low power solenoid valves and relays.

ENTRY OPTION 017

ENTRY OPTION 002

MINI-CONNECTOR

MICRO-CONNECTOR

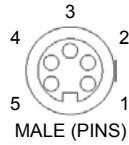

MALE (PINS)

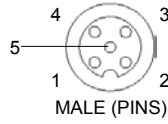

MALE (PINS)

MICRO-CONNECTOR

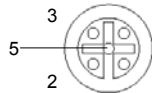

FEMALE (SOCKETS)

MICRO-CONNECTOR

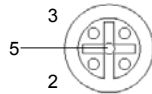

FEMALE (SOCKETS)

MICRO-CONNECTOR

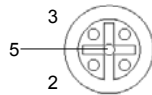

FEMALE (SOCKETS)

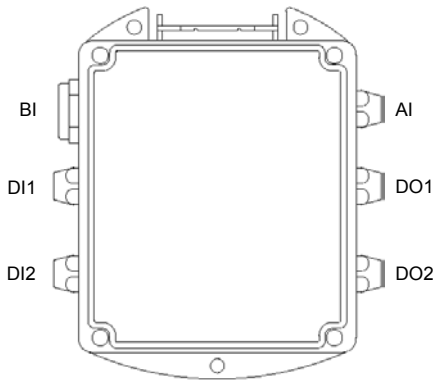

MODEL FBM92***

BUS IN (BI)

| PIN | WIRE COLOR | FBM92017 | FBM92002 | | |
|-----|------------|----------|----------|--|--|
| 1 | BROWN | Shield | Shield | | |
| 2 | WHITE | V + | V + | | |
| 3 | BLUE | V - | V - | | |
| 4 | BLACK | CAN_H | CAN_H | | |
| 5 | GRAY | CAN_L | CAN_L | | |

DISCRETE OUTPUTS (DO1 & DO2)

| | | | | | |
|---|-------|----------|----------|--|--|
| 1 | BROWN | NOT USED | NOT USED | | |
| 2 | WHITE | NOT USED | NOT USED | | |
| 3 | BLUE | OUT - | OUT - | | |
| 4 | BLACK | OUT + | OUT + | | |
| 5 | GRAY | NOT USED | NOT USED | | |

DISCRETE INPUTS (DI1 & DI2)

| | | | | | |
|---|-------|------------|------------|--|--|
| 1 | BROWN | IN + | IN + | | |
| 2 | WHITE | NOT USED | NOT USED | | |
| 3 | BLUE | 3 WIRE RTN | 3 WIRE RTN | | |
| 4 | BLACK | IN - | IN - | | |
| 5 | GRAY | NOT USED | NOT USED | | |

ANALOG INPUT (AI)

| | | | | | |
|---|-------|----------|----------|--|--|
| 1 | BROWN | AIN + | AIN + | | |
| 2 | WHITE | AIN - | AIN - | | |
| 3 | BLUE | NOT USED | NOT USED | | |
| 4 | BLACK | NOT USED | NOT USED | | |
| 5 | GRAY | NOT USED | NOT USED | | |