

FieldBlock™ Enclosure with:



AS-Interface Input/Relay Output Module (FBI96___)

These I/O Modules are designed to function as AS-Interface nodes with termination points for connecting switches/sensors, as well as Interlocked Relay Outputs to operate devices such as AC motors and other high power devices.

Inputs and Outputs

- Four (4) Discrete Inputs
- Two (2) Discrete Outputs
- Two (2) Discrete (Relay) Outputs

Features

- LED input displays for Inputs 3 & 4
- Fuse protected relay outputs

(See Page 3 detailed wiring instructions)



FieldBlock Dimensions (in mm)

Front View

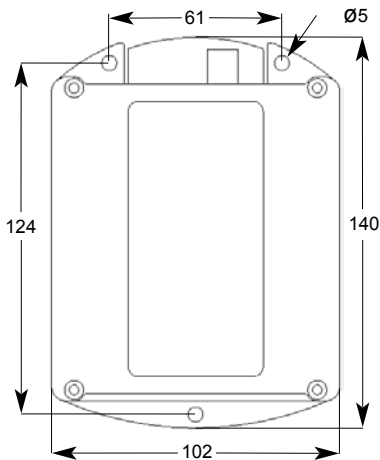

Side View

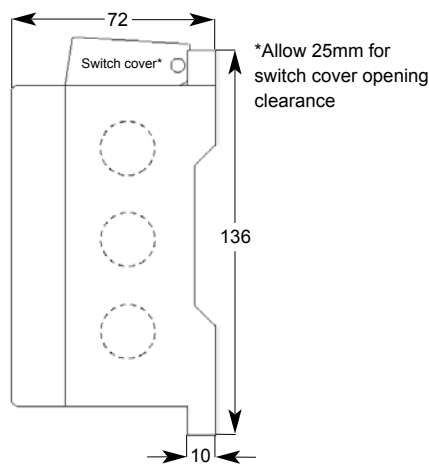

Top View

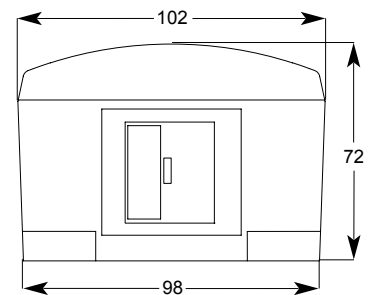

© 2001 StoneL Corporation

StoneL Corporation
One StoneL Dr
26275 US Hwy 59
Fergus Falls, MN 56537
USA

Telephone: 218.739.5774
 Toll Free: 800.843.7866
 Fax: 218.739.5776
 E-mail: sales@stonel.com
 Website: www.stonel.com

Example: **FBI96024**

	<u>Function</u>	<u>Entry Options</u>
FB 196	I/O Relay Module, Interlocked Relay Outputs, (4 DI/2 DO/2 DO relay), AS-Interface	007 (6) 1/2 NPT Conduit Entries 024* (2) 4-Pin Male Mini-Connectors, (8) 4-pin Female Micro-Connectors 025* (2) 4-Pin Male Micro-Connectors, (8) 4-pin Female Micro-Connectors 034 (10) M20 cable glands (.20 - .35 diameter cable) * See Page 4 for Connector pin-out

General Specifications

Operating Life	Unlimited	Temperature Range	-40° to +85° C (-23° to 185° F)
Materials of Construction		Enclosure Protection	NEMA 4, 4X & 6; IP67
Housing and Cover	Lexan® Polycarbonate	Warranty	
Elastomer Seals	Buna-N	Complete Assemblies	Two Years
Fasteners	Stainless Steel		

Lexan is a registered trademark of General Electric Corporation.

Mounting Instructions

Mounting The FieldBlock Enclosure

1. Locate the position where the FieldBlock enclosure will be mounted. Ensure that disconnect switch cover will have sufficient clearance to be lifted.
2. Attach the FieldBlock enclosure to a wall or other stationary flat surface using the mounting holes provided.

Attaching Cables and Connectors

1. Cable glands and connectors are provided for convenient wiring. Ensure all connections are securely tightened.
2. Follow all applicable NEC codes and other regulations.

Installing & Removing Cover

1. To insure NEMA 4, 4X and 6 ratings are maintained the cover **must be** completely closed and the gasket sealed to keep out water.
2. Tighten cover screws to 05-30 inch lbs.

AS-Interface 4 DI/2 DO/2 Relay DO Input/Output Relay Modules

Operating Voltage	AS-Interface voltage	Current Usage	40mA (no I/O enabled)
Inputs	(4) 3mA @ 28 VDC gold contact mechanical, low power reed, or 2 wire and 3 wire PNP solid state sensors	ID/IO Codes:	ID = F; IO = 7; ID1 = F; ID2 = E
Outputs (Bus Powered)	(2) 28 VDC (4 Watts total power available)	Default Address	00
Relay Outputs	(2) 120/250VAC/30VDC fused @ 2 amps	Bit Assignment	<u>Input Data</u> <u>Output Data</u> Input 1= DI0 Output 1 = DO2 Input 2= DI1 Output 2 = DO3 Input 3= DI2 Output 3 = DO0 Input 4= DI3 Output 4 = DO1
External Voltage	Up to 250 VAC; 30 VDC (For Relay Outputs)	Operating Life	Unlimited
		Warranty	Two Years

Input/Relay Output Module Wiring Diagram and Installation Notes

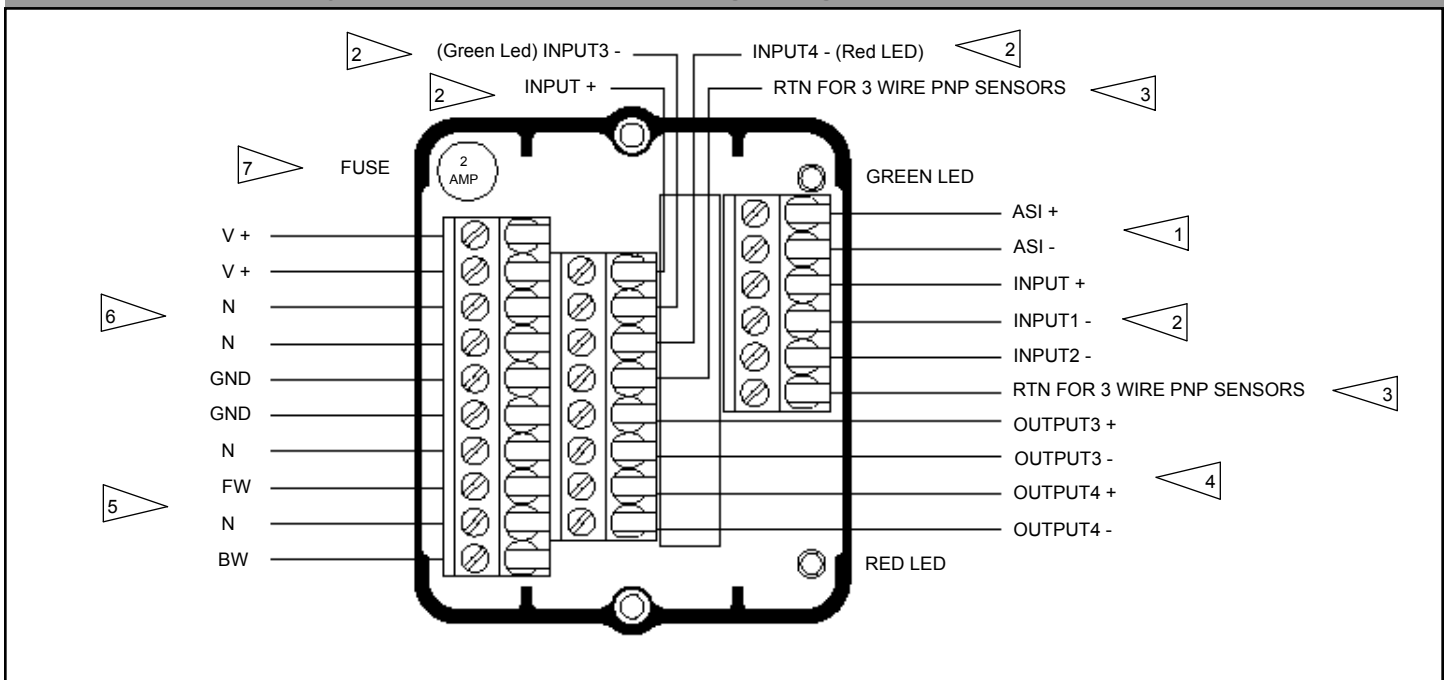

INSTALLATION NOTES:

1. AS-Interface bus communications connection points.
2. Bus powered Discrete Input connection points for low power (3mA @ 28 VDC) gold contact mechanical switches, low power reed, or 2 wire and 3 wire PNP solid state proximity sensors (max allowable current leakage of sensors 0.3mA) . Red LED is local indication of discrete Input 4 on/off status and the Green LED for discrete Input 3 on/off status.
3. Connection point for the "return" of 3 wire PNP sensors. (See Note 2)
4. 28 VDC Bus powered Discrete Outputs. (4 watts total power available)
5. Connection points for devices to be controlled by the Relay Outputs. Modules with interlocked outputs are typically used with AC motors. FW and BW represent forward and reverse operation of the motor.
6. Connection points for external 120/250VAC or 30VDC power for devices connected to the Relay Outputs. V+, V+, N, N, GND, GND are redundant termination points. The external power source feeds both Relay Outputs
7. 2 amp replaceable fuse (Part# 434162) for Relay Output protection. (See Note 6)

ENTRY OPTION 024

ENTRY OPTION 025

MINI-CONNECTOR

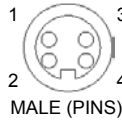

MALE (PINS)

MICRO-CONNECTOR

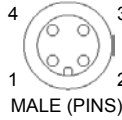

MALE (PINS)

MICRO-CONNECTOR

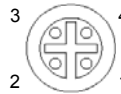

FEMALE (SOCKETS)

MICRO-CONNECTOR

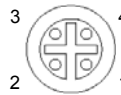

FEMALE (SOCKETS)

MICRO-CONNECTOR

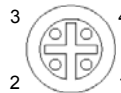

FEMALE (SOCKETS)

MINI-CONNECTOR



MALE (PINS)

MICRO-CONNECTOR

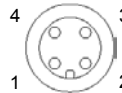

MALE (PINS)

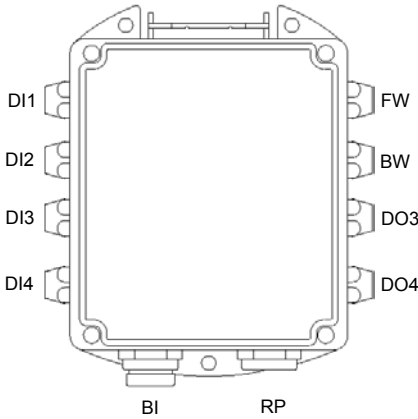

MODEL FBI96***
BUS IN (BI)

PIN	WIRE COLOR	FBI96024	FBI96025		
1	BROWN	ASI +	ASI +		
2	WHITE	NOT USED	NOT USED		
3	BLUE	ASI -	ASI -		
4	BLACK	NOT USED	NOT USED		

DISCRETE OUTPUTS (DO3 & DO4)

1	BROWN	NOT USED	NOT USED		
2	WHITE	NOT USED	NOT USED		
3	BLUE	OUT -	OUT -		
4	BLACK	OUT +	OUT +		

DISCRETE INPUTS (DI1 - DI4)

1	BROWN	IN +	IN +		
2	WHITE	NOT USED	NOT USED		
3	BLUE	3 WIRE RTN	3 WIRE RTN		
4	BLACK	IN -	IN -		

RELAY OUTPUTS (FW & BW)

1	BROWN	NOT USED	NOT USED		
2	WHITE	NOT USED	NOT USED		
3	BLUE	N	N		
4	BLACK	FW/BW	FW/BW		

RELAY POWER (RP)

1	BROWN	VR	VR		
2	WHITE	NOT USED	NOT USED		
3	BLUE	GND	GND		
4	BLACK	N	N		