



FOUNDATION Fieldbus Input/Output Modules

461052 - (Flat mount)

465014 - (DIN rail mount)

These I/O Modules are designed to function as FOUNDATION Fieldbus nodes with termination points for connecting switches/sensors, as well as outputs to operate ultra low power (Piezo) devices such solenoid valves and relays.

Inputs and Outputs

- Two (2) Discrete Inputs
- Two (2) Discrete Outputs

Features

- LED input displays for Inputs 1 & 2
- Date of Last Service
- Pre-determined output Fail State



Input/Output Module Dimensions (in mm)

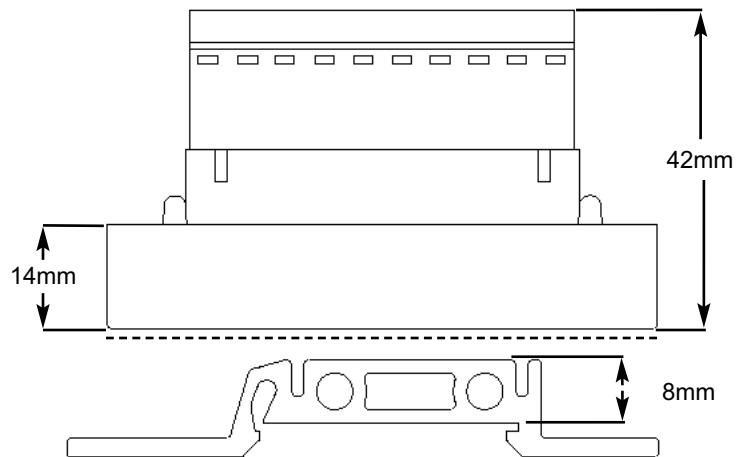
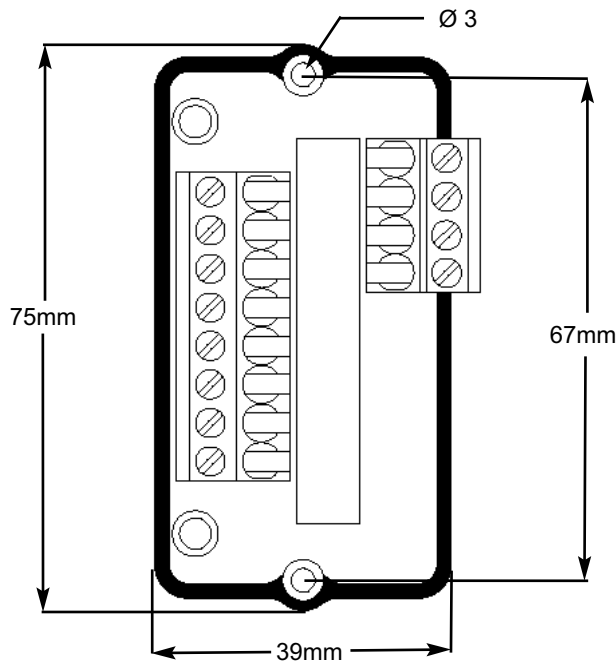

StoneL Corporation
One StoneL Dr
26271 US Hwy 59
Fergus Falls, MN 56537
USA

Telephone: 218.739.5774
 Toll Free: 800.843.7866
 Fax: 218.739.5776
 E-mail: sales@stonel.com
 Website: www.stonel.com

© 2001 StoneL Corporation

Specifications

Communication Protocol:	Foundation Fieldbus (H1)
Configuration:	(2) Discrete Inputs for low power dry contact switches capable of operating at <.045mA @ 6.5VDC or solid state PNP capable of operating at <1mA @ 6.5 VDC (2) Discrete Outputs for bus powered discrete devices that operate at ultra low power such as Piezo solenoid valves and relays. Limited to 2.0mA @ 6.5 VDC
Function Blocks	2 DI; 2 DO
Indication	Input 1 = Red LED Input 2 = Green LED
Voltage:	9-32 VDC (Bus Voltage)
Output Voltage:	6.5 VDC
Max. Output Current:	2.0mA @ 6.5 VDC
Current Draw:	16mA

Standard Channel Assignments

Channel 1 (DI1) - Discrete Input 1 (Red LED);	1 = True; 0 = False
Channel 2 (DI2) - Discrete Input 2 (Green LED);	1 = True; 0 = False
Channel 3 (DO1) - Discrete Output 1 (OUT 1);	1 = True; 0 = False
Channel 4 (DO2) - Discrete Output 2 (OUT 2);	1 = True; 0 = False

Special Channel Assignments

Channel 8 (DO1) - Discrete Output 1 (OUT 1) with state report from Discrete Input 1 (READBACK_D)
Channel 9 (DO2) - Discrete Output 2 (OUT 2) with state report from Discrete Input 2 (READBACK_D)

Valve Control Single Block Mode

Channel 10 (DO1) - Discrete Output 1 (OUT 1) with state report Discrete Inputs 1&2 (READBACK_D):

READBACK_D Values:

0 = None

1 = Discrete Input 1 is True

2 = Discrete Input 2 is True

3 = Both Discrete Inputs 1&2 are True

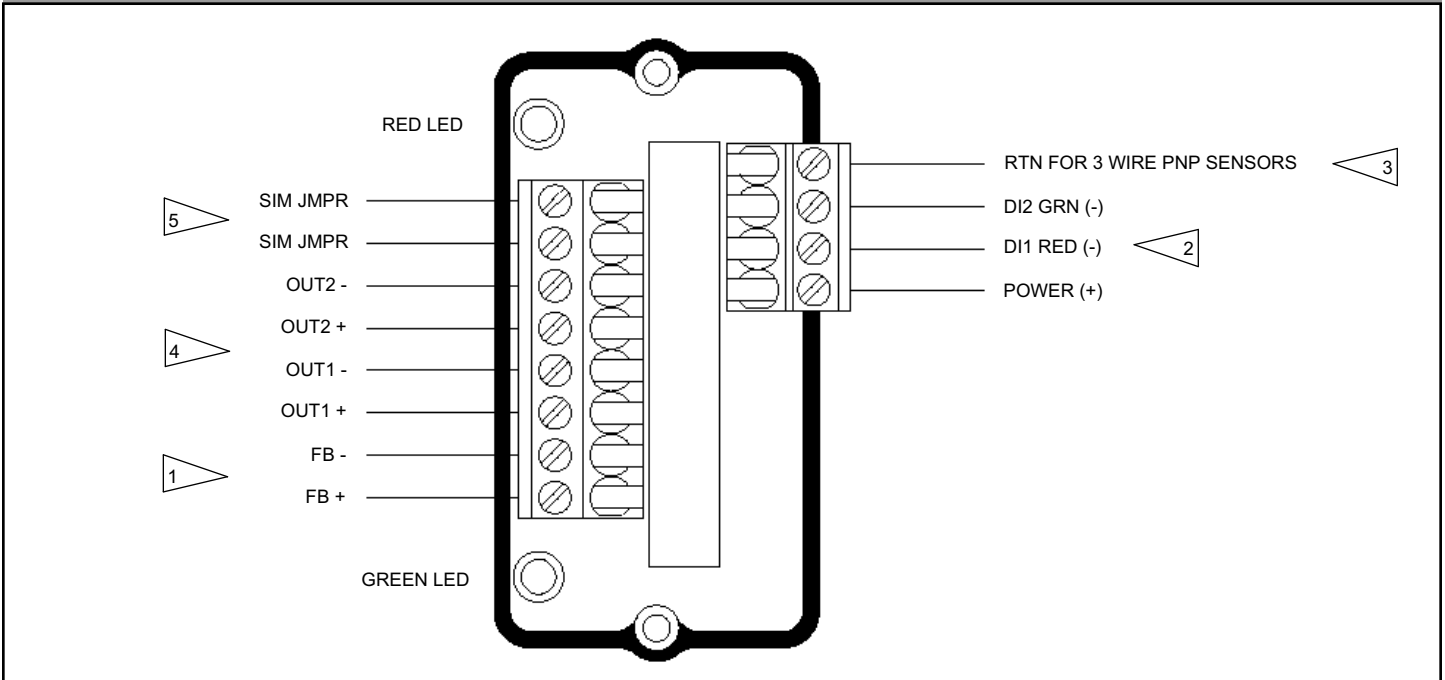

WIRING NOTES:

- 1. FOUNDATION Fieldbus bus communications connection points.
- 2. Bus powered Discrete Input connection points for low power dry contacts capable of operating at <.045mA @ 6.5VDC or solid state PNP sensors capable of operating at <1mA and 6.5VDC. Red LED is local indication of discrete input DI1 RED on/off status and the Green LED for DI2 GRN on/off status.
- 3. Connection point for the "return" of 3 wire PNP sensors. (See Note 2)
- 4. Connection points for Bus powered discrete outputs to operate ultra low power (Piezo) devices such solenoid valves and relays. Limited to 2.0mA @ 6.5VDC
- 5. These connection points not used by the consumer.

(See pages 4&5 for Intrinsically Safe (FISCO) installations)

FISCO Concept

The FISCO Concept allows the interconnection of intrinsically safe apparatus to associated apparatus not specifically examined in such combination. The criterion for such interconnection is that voltage (V_{max}), the current (I_{max}), and the power (P_i), which intrinsically safe apparatus can receive and remain intrinsically safe, considering faults, must be equal to or greater than the voltage (U_o , V_{oc} , V_t), the current (I_o , I_{sc} , I_t), and the power (P_o) which can be provided by the associated apparatus (supply unit). In addition, the maximum unprotected residual capacitance (C_i) and inductance (L_i) of each apparatus (other than the terminators) connected to the Fieldbus must be less than or equal to 5nF and 10 μ H respectively.

In each I.S. Fieldbus segment only one active source, normally the associated apparatus, is allowed to provide the necessary power for the Fieldbus system. The allowed voltage (U_o , V_{oc} , V_t) of the associated apparatus used to supply the bus must be limited to the range of 14V d.c. to 24V d.c. All other equipment connected to the bus cable has to be passive, meaning that the apparatus is not allowed to provide energy to the system, except to a leakage current of 50 μ A for each connected device. Separately powered equipment needs a galvanic isolation to insure that the intrinsically safe Fieldbus circuit remains passive.

The cable used to interconnect the devices must comply with the following parameters:

Loop resistance R' : 15 - 150 ohm/KM

Inductance per unit length L' : 0.4 - 1mH/KM

Capacitance per unit length C' : 80 - 200nF/KM

$C' = C'$ line to line + $\frac{1}{2} C'$ line to shield, if both lines are floating with respect to shield

or

$C' = C'$ line to line + C' line to shield, if one line is connected to shield

Trunk Length: \leq 1000 meters

Spur Length: \leq 30 meters

Splice Length: \leq 1 meters

FM Approved line terminators must be used on each end of the trunk cable that have the following parameters:

$R = 90 - 100$ ohms

$C = 0.0 - 2.2\mu$ F

(See Page 5 for Installation Diagram and Notes)

FOUNDATION Fieldbus I/O Modules approved for Intrinsically Safe (FISCO) installations:

461052 (2 DI/2 DO - Flat mount); 465014 (2 DI/2DO - DIN Rail mount)

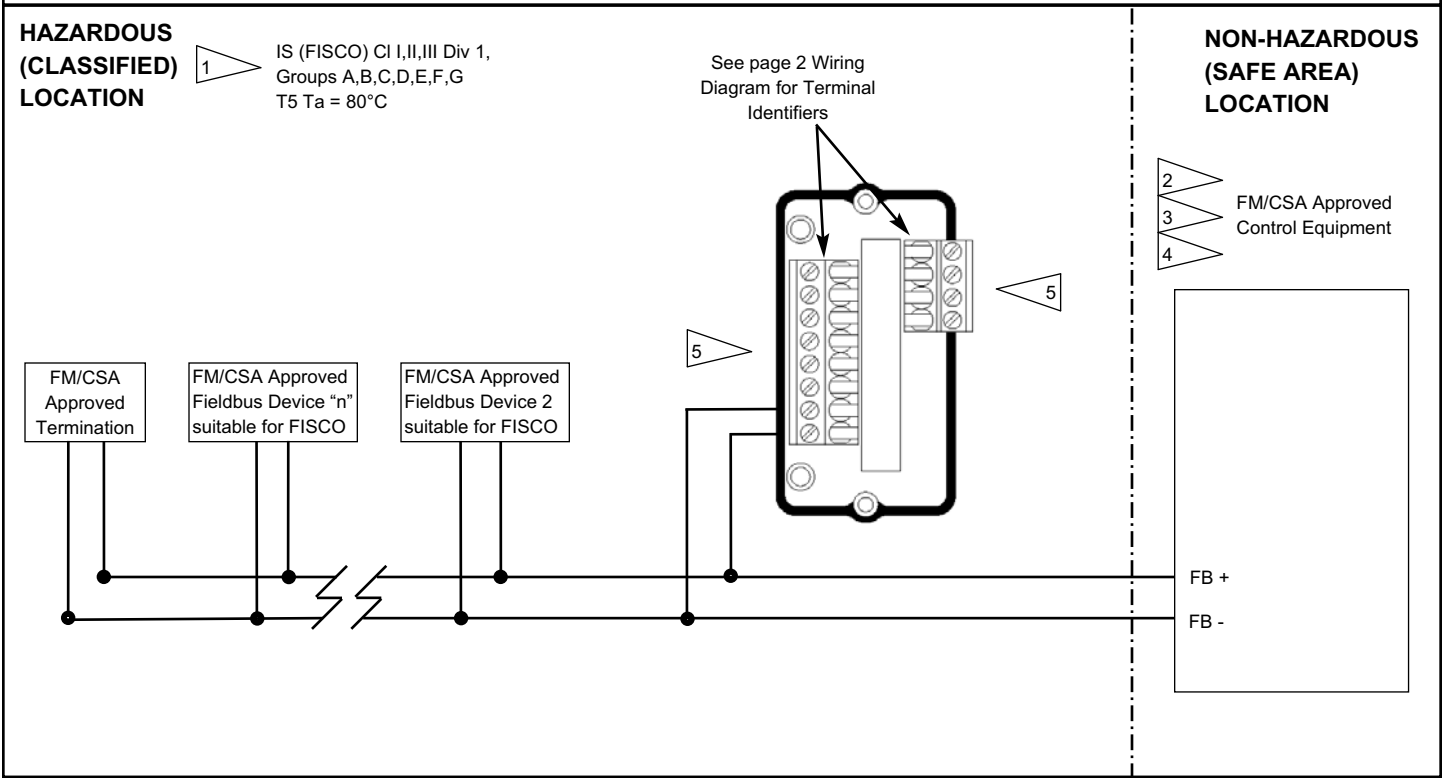

INSTALLATION NOTES:

Entity Parameters (FISCO): $U_i (V_{max}) = 30 \text{ Vdc}$; $I_i (I_{max}) = 380 \text{ mA}$; $C_i = 0.0 \text{ nF}$; $L_i = 0.0 \text{ mH}$; $P_i = 5.32 \text{ W}$

1. Installation shall be in accordance with ANSI/ISA RPA12.6.01, ANSI/NFPA 70, and the National Electrical Code or in accordance with the Canadian Electric Code.
2. Control equipment must be FM or CSA Approved Associated Apparatus suitable for FISCO.
3. Control equipment connected to FISCO barrier must not use or generate more than 250Vrms or Vdc.
4. Resistance between FISCO Intrinsically Safe Ground and earth ground must be less than 1.0 Ohm.
5. Devices connected to the Discrete Inputs and Discrete Outputs must be suitable for FISCO.
6. Substitution of components may impair hazardous location safety.
7. Approval Agency controlled Installation Diagram. No revision to diagram allowed without prior Factory Mutual or Approval Agency authority.