

Power Conditioner

StoneL Model 459014

.35 Amp Power Conditioner

This Foundation Fieldbus Power Conditioner is designed to provide power to the Fieldbus Network and attached devices. This power supply meets all Foundation Fieldbus specifications and complies with the requirements of a Type 131 power supply. (Non-IS power supply) For I.S. applications it must be used with appropriate I.S. barriers.

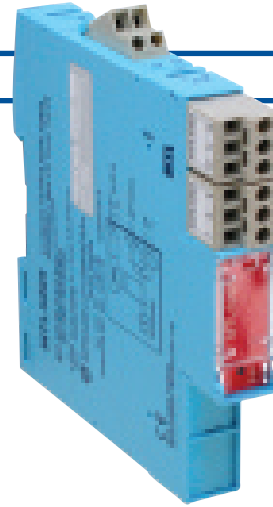

Enclosure Option



p.166



Specifications

Output Voltage	• 19 VDC +/- 2%
Output Impedance (dc)	• <2W
Output Current	• .35 Amps
Input Voltage	• 20-30VDC
Displays	• Power OK, Green LED
Operating Temp.	• -20°C to +60°C (-4° to +140°F)
Housing	• DIN rail mounting
Dimensions	• 16mm, 103mm, 113mm (L, W, H)
Ingress Protection	• IP20, field enclosure required
Approvals	<ul style="list-style-type: none"> • Cenelec: EEx nA IIC T4 • FM: Class 1 Division 2 Groups A,B,C,D • CSA: Class 1 Division 2 Groups A,B,C,D
Weight	136g (0.3 pounds)

Schematic Drawing

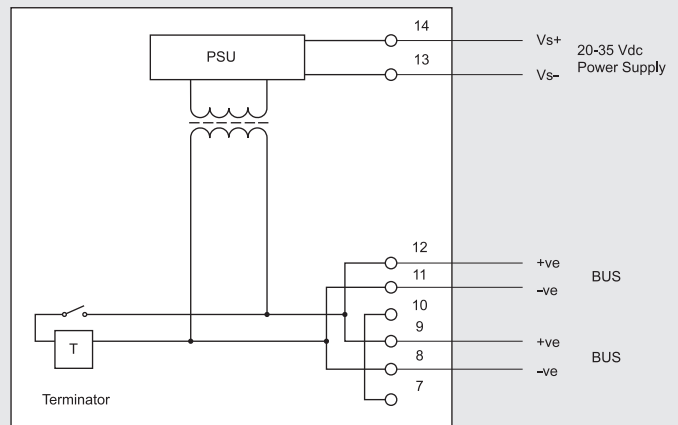

Dimensions (in mm)

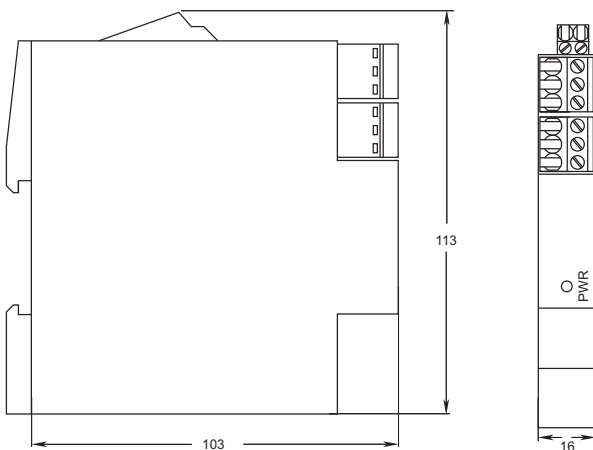

Wiring Diagram

