



Installation & Adjusting Instructions

Mounting to Namur Style Actuator

1. Attach mounting plate to monitor using fasteners and lockwashers provided.
2. Align namur shaft so that it fits in the groove on the top of the actuator shaft.
3. Attach mounting plate to actuator using fasteners and lockwashers provided.
4. Operate actuator to full open and full closed positions to check for proper coupling alignment. Eccentricity of shaft must be no greater than .01" from centerline. Adjust if necessary and snug-down adjustment bolts tightly.

Mounting to Non-Namur Actuator

1. Attach mounting plate to monitor using fasteners and lockwashers provided.
2. Remove spacer screw and attach spring torque coupler or drive block to the shaft with spacer screw or screw provided with mounting kit. Align drive block or spring torque coupler with mating shaft and lower until the mounting bracket meets its mating surface. Ensure the coupler or drive block have fully engaged the output shaft of the device to be monitored.
3. Attach mounting plate to actuator using fasteners and lockwashers provided.
4. Operate actuator to full open and full closed positions to check for proper coupling alignment. Eccentricity of shaft must be no greater than .01" from centerline. Adjust if necessary and snug-down adjustment bolts tightly.

Visual Indicator Adjustment

5. Remove cover from unit. Lift indicator drum to disengage from splined drive. Rotate indicator until it reaches the desired position. Slide indicator drum onto splined drive to re-engage. Replace the cover.

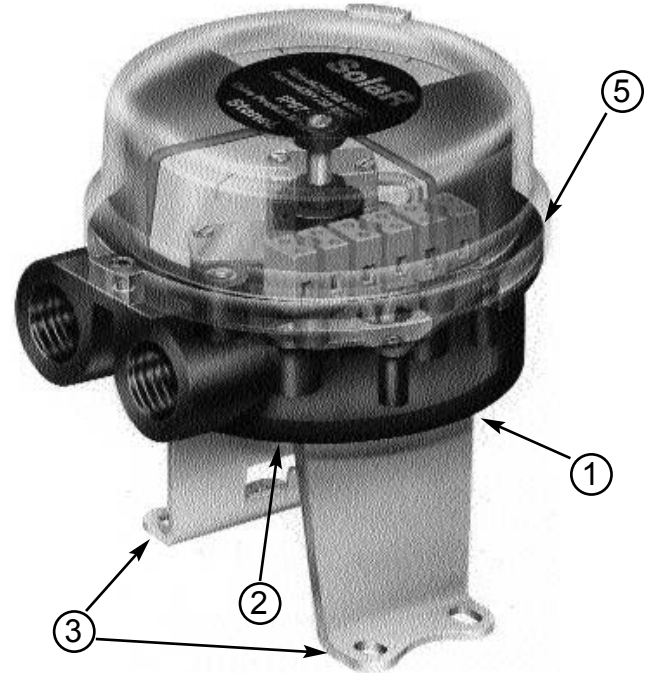

Installing & Removing Cover

(Refer to Diagram 1 and 2 below)

The cover goes from open to full closed with a turn of about 25 degrees.

Removing the Cover

- I. Loosen cover lock screw to where the bottom of the screw head is flush with top of the cover locking tab. This is the non-locking position and the way it is shipped from the factory.
- II. Remove the cover by turning it approximately 25 degrees counterclockwise until it hits the stop and lift the cover off.

Replacing the Cover

- I. The cover O'Ring **must** be in place on the housing body.
- II. Place the cover on the housing with the cover locking tab 25 degrees counterclockwise from the hole between the conduit entries (see diagram 1). The cover will fit properly on the housing **only** in this position.
- III. Twist the cover 25 degrees clockwise until the cover locking screw is directly over the hole between the conduit entries (see diagram 2).
- IV. To insure NEMA 4 & 4X ratings the cover **must be** completely closed and the O'Ring sealed to keep out water. This is achieved when the cover is closed and locking screw can be easily screwed in until the top of the screw head is flush with the top of the cover locking tab. Check the cover O'Ring to make sure it is in place and not buckled.

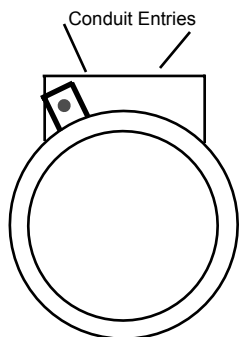

Cover Open Position Diagram 1

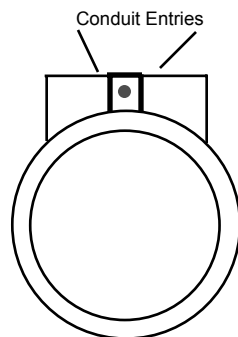

Cover Closed Diagram 2



StoneL Corporation
 One StoneL Dr
 26275 US Hwy 59
 Fergus Falls, MN 56537
 USA

Telephone: 218.739.5774
 Toll Free: 800.843.7866
 Fax: 218.739.5776
 E-mail: sales@stonel.com
 Website: www.stonel.com

Specifications

Outputs: Namur Sensors (DIN 19234)
 Current Ratings: Target Present Current < 1.0 mA (LED = OFF)
 Target Absent Current > 3.0 mA (LED = ON)
 Voltage Range: 5 to 25 VDC
 Temperature Range: (-14 F to 180 F)

Operating Life: Unlimited
 Warranty: 2 Years

Use with intrinsically safe repeater barrier. Namur sensors fully conform to DIN 19234 standard.

Touch & Tune™ Switch Setting

Notes: All adjustments assume you are looking down on the top of the sensors. The edge of the cam metal strip will be at the edge of the sensor target when activation occurs. When the cam is released be sure it slides fully onto the spline. One spline tooth setting is 4 1/2°.

I. Valve Closed to Open in counter-clockwise rotation (See Fig. 1 below):

6. With the valve in the "Closed" position, set the bottom cam so that the metal activation strip is centered on the bottom sensor target and the top cam is 180° from the bottom cam. Connect power supply and ammeter to the bottom switch.
- 6a. Lift up bottom cam and rotate counter-clockwise until the ammeter reads >3 mA, then rotate clockwise until the ammeter reads <1mA. Release the cam.
- 6b. Move valve to the "Open" position. Connect power supply and ammeter to the top switch. Push down top cam and rotate counter-clockwise until the ammeter reads <1 mA. Release cam.

II. Valve Closed to Open in clockwise rotation (See Fig. 2 below):

7. With the valve in the "Closed" position, set the bottom cam so that the metal activation strip is centered on the bottom sensor target and the top cam is 180° from the bottom cam. Connect power supply and ammeter to the bottom switch.
- 7a. Lift up bottom cam and rotate clockwise until the ammeter reads >3 mA, then rotate counter-clockwise until the ammeter reads <1mA. Release the cam.
- 7b. Move valve to the "Open" position. Connect power supply and ammeter to the top switch. Push down top cam and rotate counter-clockwise until the ammeter reads <1 mA. Release cam.

To Bench Test a Namur Sensor:

Use StoneL Light Read Tester or use a 12 VDC power supply and an ammeter. No series load resistor required.

Wiring Diagram

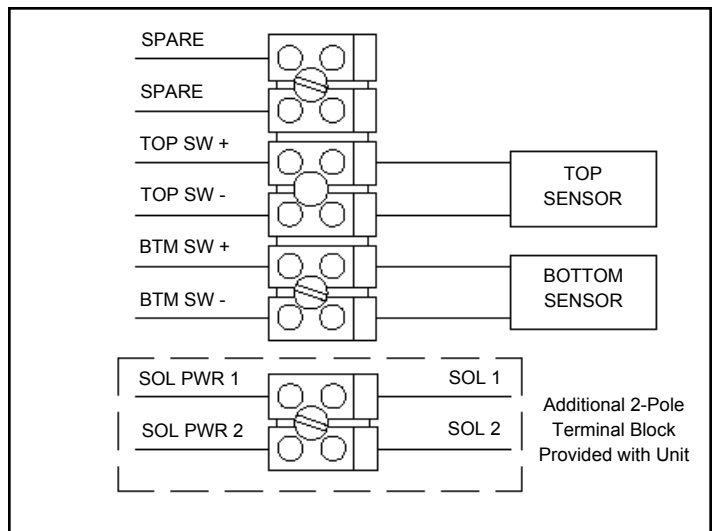

Sensor Settings

Cams Set for Counter-Clockwise Rotation

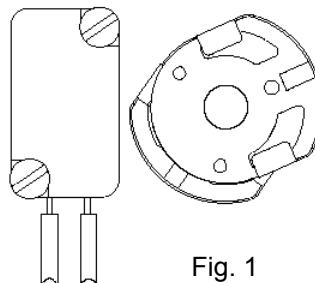

Cams Set for Clockwise Rotation

