

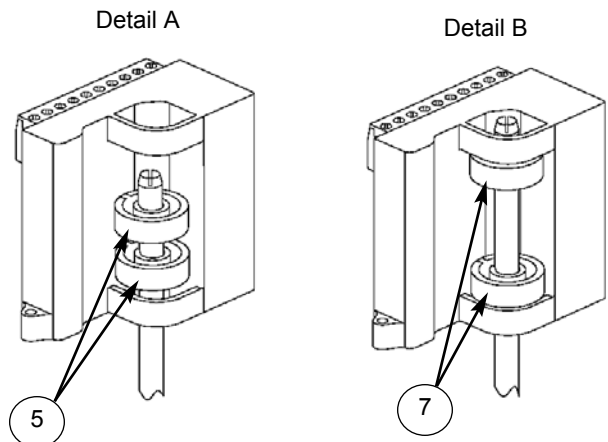

# Installation & Adjusting Instructions

## Prism™ Mounting

1. Thread the Trigger Shaft onto the actuation system stem.
2. Place provided o-ring in groove on the bottom of the Mounting Coupler and slide over the Trigger Shaft. Secure Mounting Coupler to the actuation system. Fastening of Mounting Coupler to the actuation system will be either flange mounted or threaded. (Dependent on manufacturer of valve assembly)
3. Remove the Prism's Cover.
4. Slide the Prism Switch Assembly over the Trigger Shaft via the Mounting Coupler socket located on the bottom of the Switch Assembly. Do not seat the Switch Assembly onto the Mounting Coupler. The Trigger Shaft should now be approximately midway between upper and lower Cam Stops on the Dual Module. (See Detail A)
5. While supporting the Switch Assembly with one hand, place the two Trigger Cams onto the Trigger Shaft between the cam stops. (See Detail A)
6. Fully seat the Switch Assembly onto the Mounting Coupler. Secure the Switch Assembly to the Mounting Coupler by tightening the set screw located on the bottom of the Switch Assembly, opposite of the conduit entries. On mounting systems for 2" and larger valves, thread the provided 6/32 screw into the top of the Trigger Shaft. (See Inset - AA)
7. To set the Cam Triggers, slide the upper trigger until it touches the upper cam stop (or 6/32 screw) and push down the lower trigger until it touches the lower cam stop. Cycle the actuator and the triggers will automatically be set to the proper position. (See Detail B)
8. Perform applicable field wiring and replace Prism Cover. (Applicable wiring diagrams and connector pin-out guides located on Page 4 of this document)

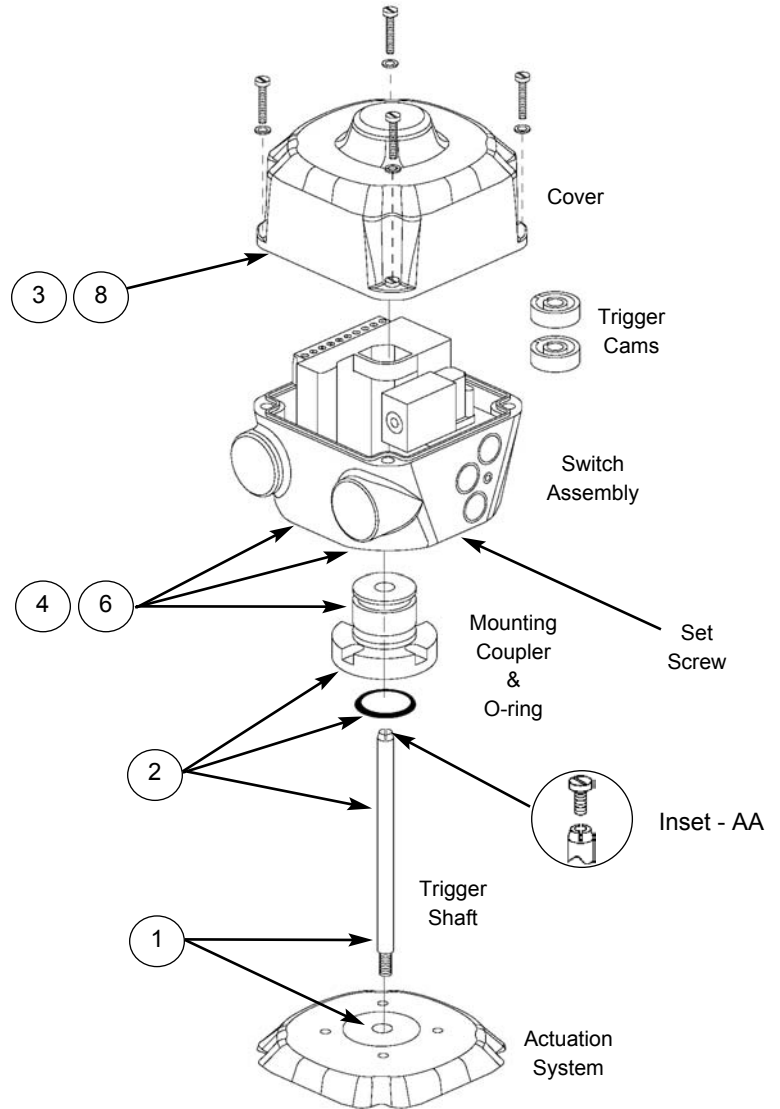

StoneL Corporation  
 One StoneL Dr  
 26275 US Hwy 59  
 Fergus Falls, MN 56537  
 USA  
 Telephone: 218.739.5774  
 Toll Free: 800.843.7866  
 Fax: 218.739.5776  
 E-mail: sales@stonel.com  
 Website: www.stonel.com

# PRISM Model Selector

	Function	Pneumatic Valve	Conduit/Connectors	Visual Indicator	Valve Size
<b>PM</b>	<b>33</b> (2) SST N.O. Sensors <b>34</b> (2) SST N.C. Sensors <b>44</b> (2) NAMUR Sensors <b>92</b> DeviceNet VCT** <b>93</b> Foundation Fieldbus VCT* (Bus Power Outputs; I.S.) <b>94</b> Foundation Fieldbus VCT** (Externally Powered Outputs) <b>95</b> Modbus VCT** <b>96</b> AS-Interface VCT** <b>97</b> AS-Interface VCT (Ext Add)** * For use with pneumatic valve option 11 or 1A only ** For use with pneumatic valve option 11, 1B or 1D only	<b>11</b> No Pneumatic Valve <b>1A</b> 3-way/Piezo* <b>1B</b> 3-way/24 VDC/1.8 W <b>1C</b> 3-way/120 VAC/5.4 W <b>1D</b> 3-way/24 VDC/0.5 W <b>1E</b> 3-way/12 VDC (I.S.)**  * For use with Function 93 only ** For use with Function 44 only	<b>S02</b> (2) 1/2" NPT <b>S05</b> (2) M20 <b>S09</b> (2) Cable Glands <b>S11</b> (1) 5-Pin Mini-Connector <b>S13</b> (1) 4-Pin Micro-Connector <b>S14</b> (2) 4-Pin Micro-Connector <b>S15</b> (1) 5-Pin Micro-Connector <b>S16</b> (1) 5-Pin Micro-Connector & (1) 4-Pin Micro Connector	<b>R</b> Red Closed/ Green Open <b>G</b> Green Closed/ Red Open	<b>S</b> Stroke less than 2" <b>L</b> Stroke from 2" to 4"
<b>Model Number Example: PM961BS02RS</b>					

## General Specifications and Ratings

<b>Materials of Construction</b> Housing & Cover: Polycarbonate Fasteners: Stainless Steel Triggering Cams: Stainless Steel Banded Polycarbonate Mounting System: Stainless Steel O-Rings: Buna-N Valve Manifold: Polysulfone with Stainless Steel Reinforced NPT Ports	Operating Life: One Million Cycles Temperature Range: -40° C to 80° C (-40° F to 180° F) <b>Enclosure Protection</b> NEMA: 4, 4X, 6; IP67 <b>Hazardous Location Ratings</b> Nonincendive: Class I&II, Div 2, All Gas Groups <b>Warranty</b> Dual Modules/VCTs: Five Years Mechanical Components: Two Years
---	--

## Dimensions (mm)

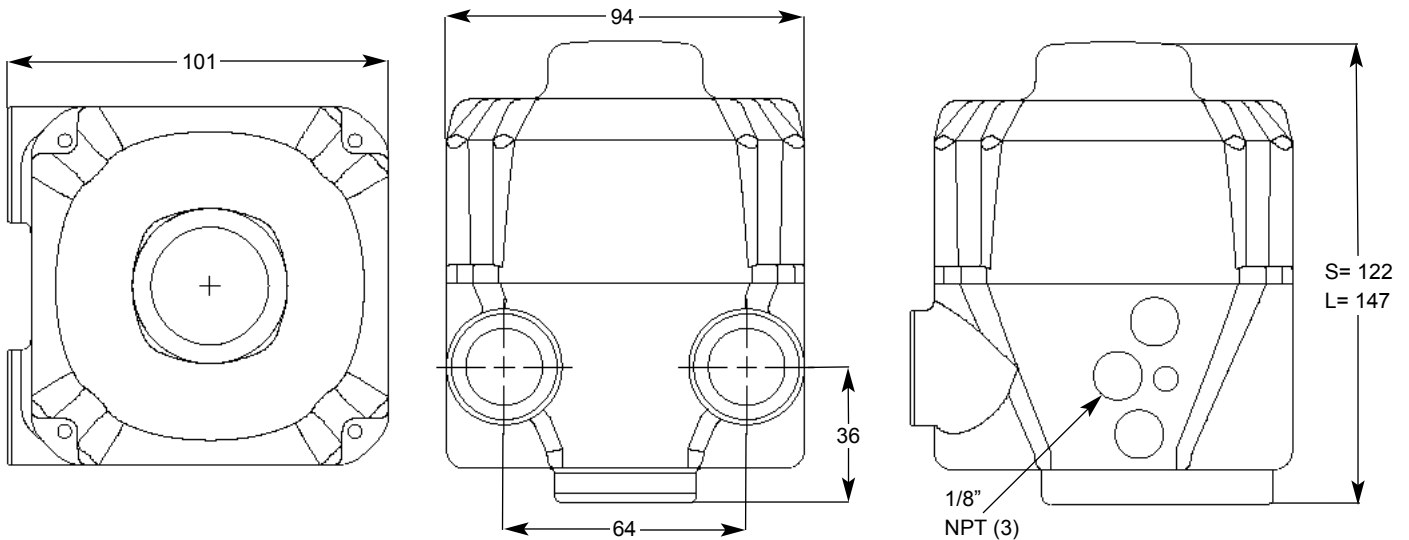

### General Pneumatic Specifications

**Configuration:** 3-Way, 2-Position, Spring Return  
**Porting:** 1/8 NPT (all pressurized ports)  
**Rebreather Port:** 4-40 size  
**Operating Pressure:** 40 psi to 120 psi (2.6 to 8.0 bar)  
**Flow Rating:** 0.1 Cv (1.4 Kv)  
**Rebreather:** Standard on all models; Diverts air from exhausting cylinder into actuator spring side, Excess air exhausted to the atmosphere  
  
**Valve Cycle Time:**  
 1/2" Stroke To Open = < 1 sec. To Close = < 1 sec.  
 1 1/8" Stroke To Open = 3.4 sec. To Close = 3.1 sec.  
**Operating Life:** One Million Cycles

### Solenoid Coil Specifications

**120 VAC** (with burn-out proof coil)  
**Power:** 5.4 Watts  
**Inrush Current:** 0.09 Amps @ 120 VAC  
**Holding Current:** 0.06 Amps @120 VAC

### 24 VDC

**Power:** 1.8 Watts (1B); 0.5 Watts (1D)  
**Current Draw:** 0.075 Amps (1B); 0.02 Amps (1D)  
**Temperature Range:** -18° C to 50° C (0° F to 120° F)  
**Filtration Requirements:** 40 Microns

### 12 VDC (Intrinsically Safe)

**Power:** 0.5 Watts  
**Current Draw:** 0.04 Amps  
**Temperature Range:** -18° C to 50° C (0° F to 120° F)  
**Filtration Requirements:** 40 Microns

### Piezo

**Operating Voltage:** 5.5 VDC to 9.0 VDC  
**Current Draw:** 2.0 mA @ 6.5 VDC  
**Temperature Range:** -10° C to 60° C (14° F to 140° F)  
**Filtration Requirements:** 30 Microns  
**Hazardous Ratings:** EEx ia IIC T6

## Pneumatic Valve Schematic

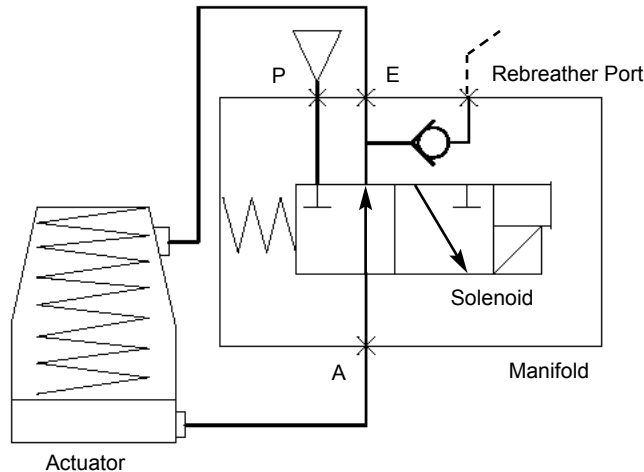

## Pneumatic Valve Component Locator

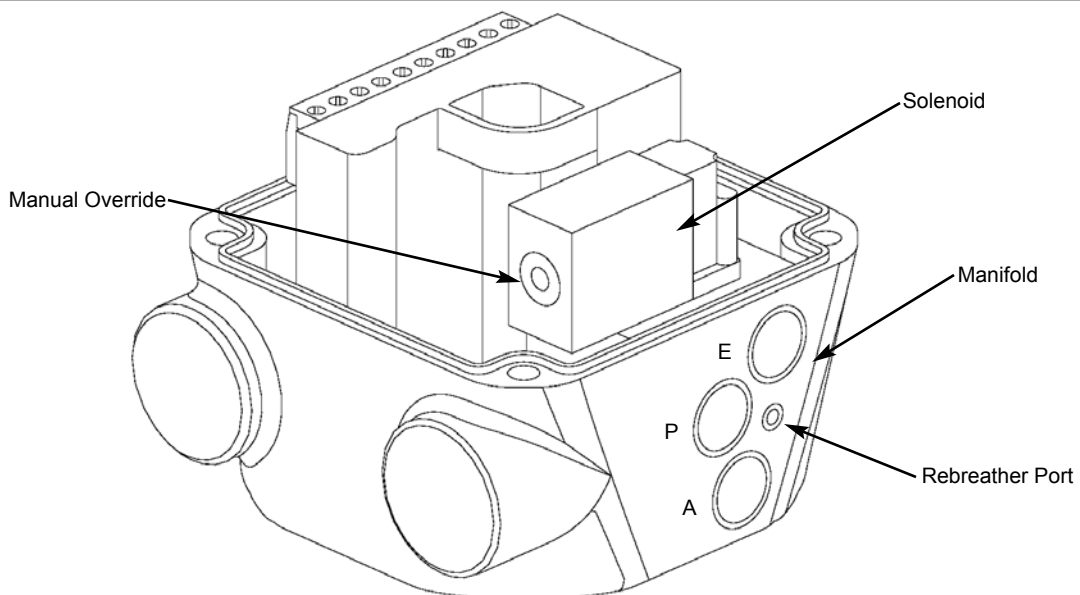

### 34 Dual Module Specifications

Sensors: (2) NC 2-wire Solid State Sensors  
 Voltage Range: 8 to 125 VDC, 24 to 125 VAC  
 Maximum Current:  
     *Inrush* 2.0 Amps@125V AC/DC  
     *Continuous* 0.3 Amps@125V AC/DC

Minimum On Current: 2.0 mA  
 Leakage Current:  
     *DC Circuits* 0.15 mA  
     *AC Circuits* 0.25 mA  
 Max Voltage Drop 6.5 Volts @ 10 mA  
                           7.5 Volts @ 100mA

**To Bench Test a Dual Module SST Sensor:** Use StoneL Light Read Tester. Or use a 24 Vdc or 120 Vac power supply with series load resistor (2K - 6K Ω).

**WARNING:**

**FAILURE TO USE A SERIES LOAD RESISTOR WHEN BENCH TESTING SENSORS WITH A POWER SUPPLY WILL RESULT IN PERMANENT DAMAGE TO THE UNIT**

## Wiring Diagram/Connector Pin-Out

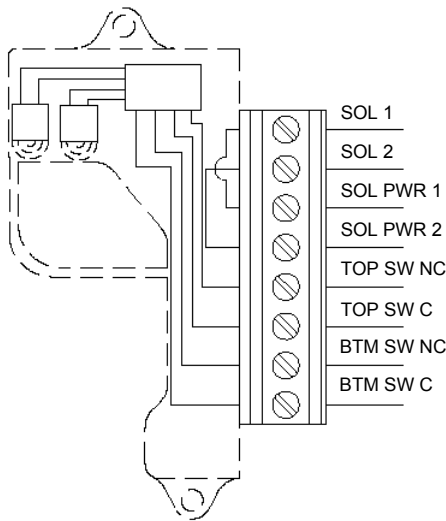

### Connector Option (S11)

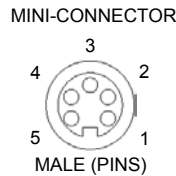

PIN	PM3411S11XX	PM341BS11XX	PM341CS11XX
1	BTM C	TOP/BTM C	TOP/BTM C
2	BTM NC	BTM NC	BTM NC
3	NOT USED	TOP NC	TOP NC
4	TOP NC	SOL PWR 2	SOL PWR 2
5	TOP C	SOL PWR 1	SOL PWR 1

### Connector Option (S13)

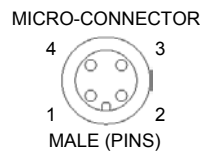

PIN	PM3411S13XX
1	TOP NC
2	BTM NC
3	BTM C
4	TOP C

### Connector Option (S16)

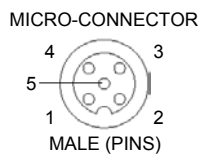

PIN	PM3411S16XX
1	TOP NC
2	BTM NC
3	SOL PWR 1
4	SOL PWR 2
5	TOP/BTM C
XX	XXXXXXXXXX
1	NOT USED
2	NOT USED
3	SOL 1
4	SOL 2

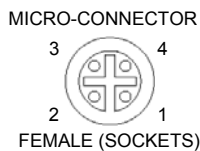

### Connector Option (S15)

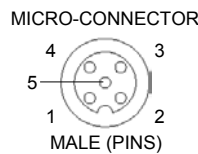

PIN	PM3411S15XX	PM341BS15XX	PM341CS15XX
1	BTM C	TOP/BTM C	TOP/BTM C
2	BTM NC	BTM NC	BTM NC
3	NOT USED	TOP NC	TOP NC
4	TOP NC	SOL PWR 2	SOL PWR 2
5	TOP C	SOL PWR 1	SOL PWR 1