

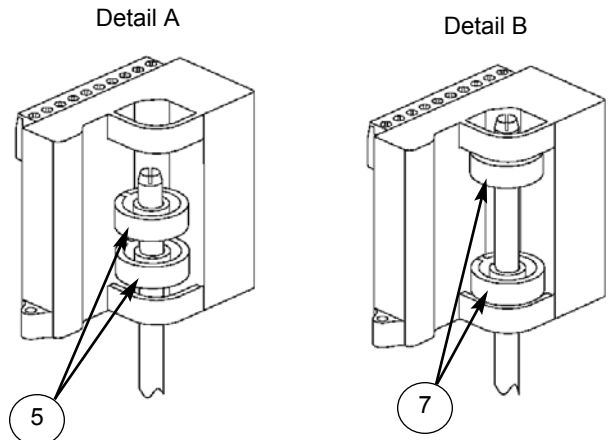

Installation & Adjusting Instructions

Prism™ Mounting

1. Thread the Trigger Shaft onto the actuation system stem.
2. Place provided o-ring in groove on the bottom of the Mounting Coupler and slide over the Trigger Shaft. Secure Mounting Coupler to the actuation system. Fastening of Mounting Coupler to the actuation system will be either flange mounted or threaded. (Dependent on manufacturer of valve assembly)
3. Remove the Prism's Cover.
4. Slide the Prism Switch Assembly over the Trigger Shaft via the Mounting Coupler socket located on the bottom of the Switch Assembly. Do not seat the Switch Assembly onto the Mounting Coupler. The Trigger Shaft should now be approximately midway between upper and lower Cam Stops on the Dual Module. (See Detail A)
5. While supporting the Switch Assembly with one hand, place the two Trigger Cams onto the Trigger Shaft between the cam stops. (See Detail A)
6. Fully seat the Switch Assembly onto the Mounting Coupler. Secure the Switch Assembly to the Mounting Coupler by tightening the set screw located on the bottom of the Switch Assembly, opposite of the conduit entries. On mounting systems for 2" and larger valves, thread the provided 6/32 screw into the top of the Trigger Shaft. (See Inset - AA)
7. To set the Cam Triggers, slide the upper trigger until it touches the upper cam stop (or 6/32 screw) and push down the lower trigger until it touches the lower cam stop. Cycle the actuator and the triggers will automatically be set to the proper position. (See Detail B)
8. Perform applicable field wiring and replace Prism Cover. (Applicable wiring diagrams and connector pin-out guides located on Page 4 of this document)

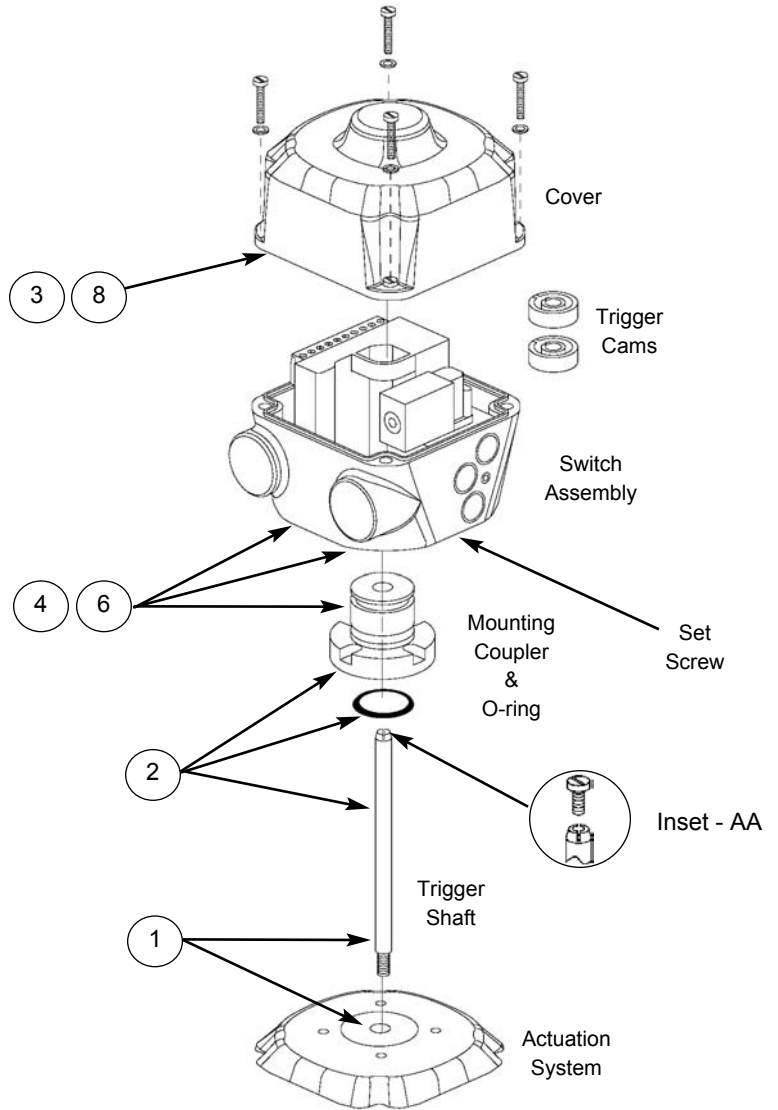

StoneL Corporation
 One StoneL Dr
 26275 US Hwy 59
 Fergus Falls, MN 56537
 USA
 Telephone: 218.739.5774
 Toll Free: 800.843.7866
 Fax: 218.739.5776
 E-mail: sales@stonel.com
 Website: www.stonel.com

PRISM Model Selector

	Function	Pneumatic Valve	Conduit/Connectors	Visual Indicator	Valve Size
PM	33 (2) SST N.O. Sensors 34 (2) SST N.C. Sensors 44 (2) NAMUR Sensors 92 DeviceNet VCT** 93 Foundation Fieldbus VCT* (Bus Power Outputs; I.S.) 94 Foundation Fieldbus VCT** (Externally Powered Outputs) 95 Modbus VCT** 96 AS-Interface VCT** 97 AS-Interface VCT (Ext Add)** * For use with pneumatic valve option 11 or 1A only ** For use with pneumatic valve option 11, 1B or 1D only	11 No Pneumatic Valve 1A 3-way/Piezo* 1B 3-way/24 VDC/1.8 W 1C 3-way/120 VAC/5.4 W 1D 3-way/24 VDC/0.5 W 1E 3-way/12 VDC (I.S.)** * For use with Function 93 only ** For use with Function 44 only	S02 (2) 1/2" NPT S05 (2) M20 S09 (2) Cable Glands S11 (1) 5-Pin Mini-Connector S13 (1) 4-Pin Micro-Connector S14 (2) 4-Pin Micro-Connector S15 (1) 5-Pin Micro-Connector S16 (1) 5-Pin Micro-Connector & (1) 4-Pin Micro Connector	R Red Closed/ Green Open G Green Closed/ Red Open	S Stroke less than 2" L Stroke from 2" to 4"
Model Number Example: PM961BS2RS					

General Specifications and Ratings

Materials of Construction Housing & Cover: Polycarbonate Fasteners: Stainless Steel Triggering Cams: Stainless Steel Banded Polycarbonate Mounting System: Stainless Steel O-Rings: Buna-N Valve Manifold: Polysulfone with Stainless Steel Reinforced NPT Ports	Operating Life: One Million Cycles Temperature Range: -40° C to 80° C (-40° F to 180° F) Enclosure Protection NEMA: 4, 4X, 6; IP67 Hazardous Location Ratings Nonincendive: Class I&II, Div 2, All Gas Groups Warranty Dual Modules/VCTs: Five Years Mechanical Components: Two Years
---	--

Dimensions (mm)

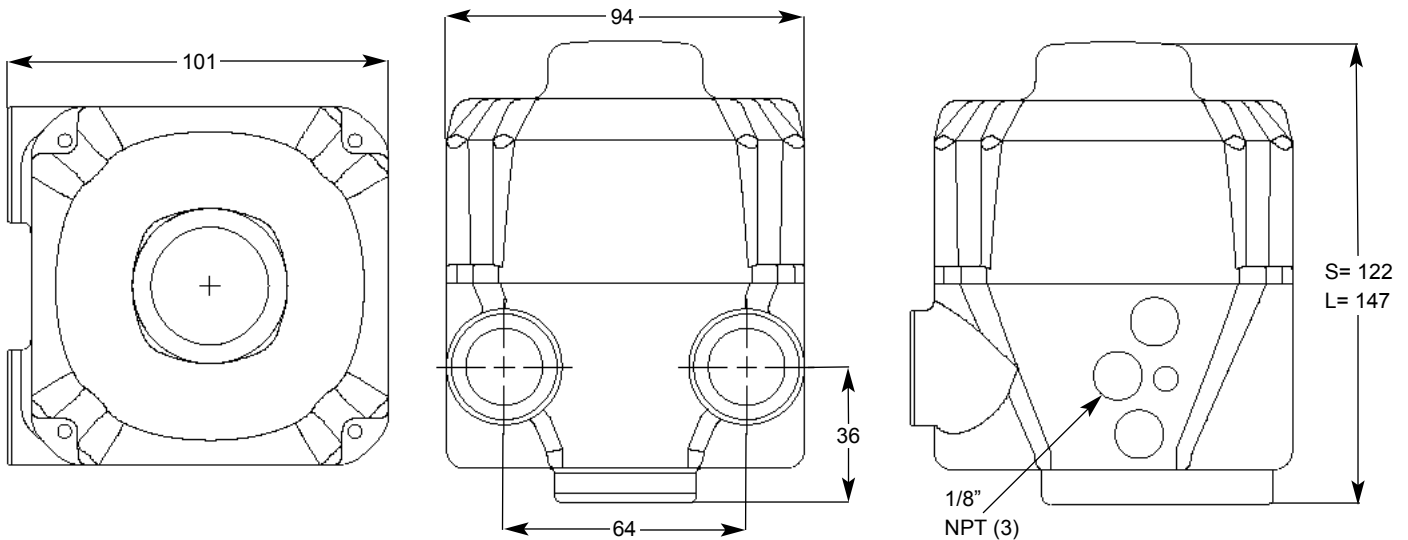

General Pneumatic Specifications

Configuration: 3-Way, 2-Position, Spring Return
 Porting: 1/8 NPT (all pressurized ports)
 Rebreather Port: 4-40 size
 Operating Pressure: 40 psi to 120 psi (2.6 to 8.0 bar)
 Flow Rating: 0.1 Cv (1.4 Kv)
 Rebreather: Standard on all models; Diverts air from exhausting cylinder into actuator spring side, Excess air exhausted to the atmosphere

Valve Cycle Time:
 1/2" Stroke To Open = < 1 sec. To Close = < 1 sec.
 1 1/8" Stroke To Open = 3.4 sec. To Close = 3.1 sec.
 Operating Life: One Million Cycles

24 VDC

Power: 1.8 Watts (1B); 0.5 Watts (1D)
 Current Draw: 0.075 Amps (1B); 0.02 Amps (1D)
 Temperature Range: -18° C to 50° C (0° F to 120° F)
 Filtration Requirements: 40 Microns

12 VDC (Intrinsically Safe)

Power: 0.5 Watts
 Current Draw: 0.04 Amps
 Temperature Range: -18° C to 50° C (0° F to 120° F)
 Filtration Requirements: 40 Microns

Piezo

Operating Voltage: 5.5 VDC to 9.0 VDC
 Current Draw: 2.0 mA @ 6.5 VDC
 Temperature Range: -10° C to 60° C (14° F to 140° F)
 Filtration Requirements: 30 Microns
 Hazardous Ratings: EEx ia IIC T6

Solenoid Coil Specifications

120 VAC (with burn-out proof coil)

Power: 5.4 Watts
 Inrush Current: 0.09 Amps @ 120 VAC
 Holding Current: 0.06 Amps @ 120 VAC

Pneumatic Valve Schematic

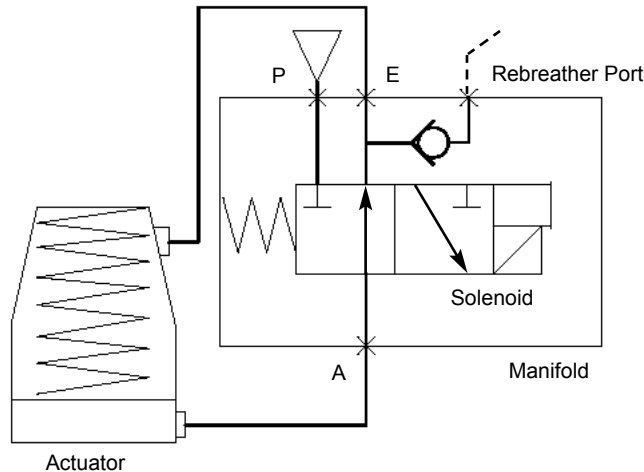

Pneumatic Valve Component Locator

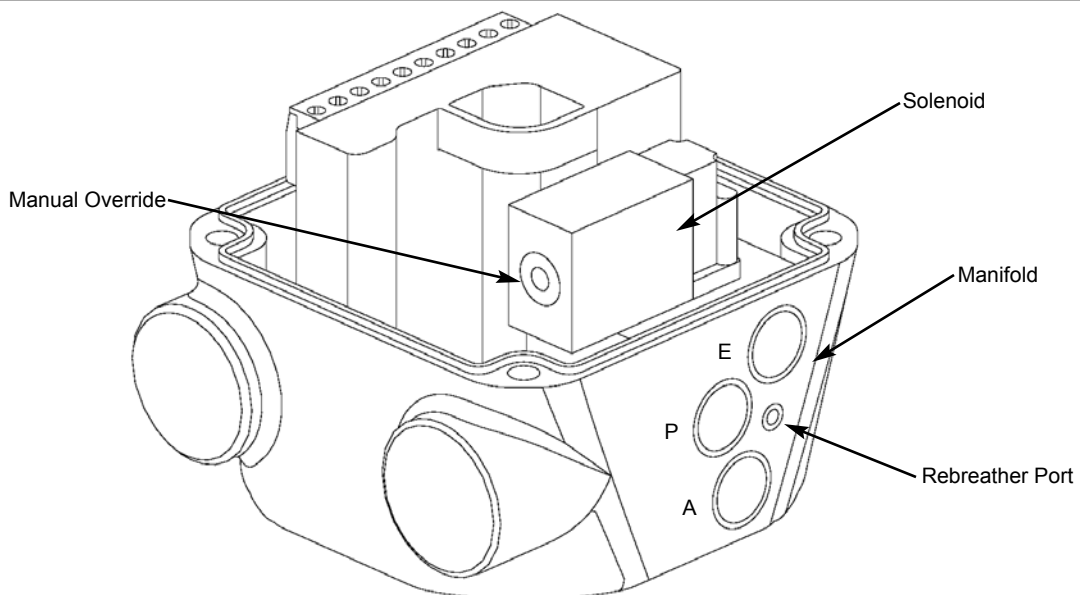

AS-Interface VCT Specifications

Communication Protocol: AS-Interface
 Configuration: (2) Discrete Inputs (Sensors)
 (2) Auxiliary Discrete Inputs
 (1) Discrete Output (Solenoid)
 Voltage: 24-30 VDC (AS-I Voltage)
 Output Voltage: 24 VDC
 Max. Output Current: 100mA
 Max. Output Power: 2.4 Watts

ID/IO Codes: ID = A; IO = 4; ID1 = 7; ID2 = E
 Default Address: 0A
 Bit Assignment:

Inputs	Outputs
Bit 1 = Aux Input 1	Bit 1 = Not Used
Bit 2 = Aux input 2	Bit 2 = Not Used
Bit 3 = Green LED	Bit 3 = OUT 1*
Bit 4 = Red LED	Bit 4 = Not Used

* Discrete Output 1 is used for units with integral solenoid

To Bench Test AS-Interface VCT: To test Sensors use 24 VDC power supply across ASI + and ASI -. No series resistor needed. A functioning AS-Interface network is required to test communications.

WARNING:

DO NOT APPLY EXTERNAL POWER TO THE OUTPUT TERMINALS. THIS WILL RESULT IN PERMANENT DAMAGE TO THE UNIT.

Wiring Diagram/Connector Pin-Out

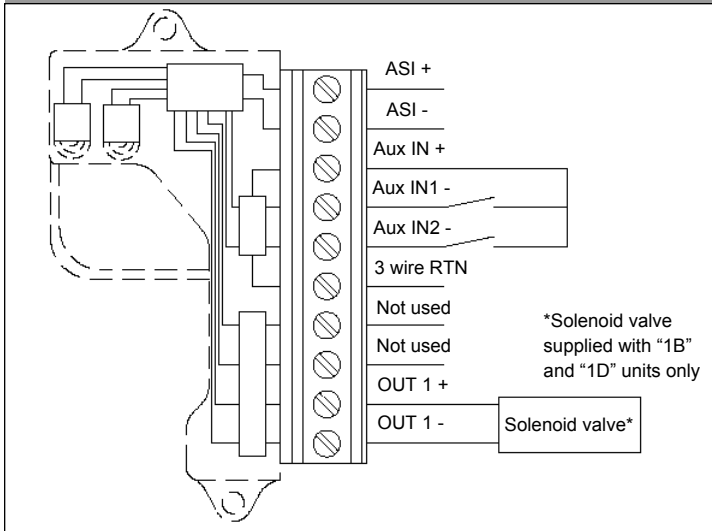

Connector Option (S13)

PIN	PM9711S13XX	PM971BS13XX	PM971DS13XX
1	ASI +	ASI +	ASI +
2	NOT USED	NOT USED	NOT USED
3	ASI -	ASI -	ASI -
4	NOT USED	NOT USED	NOT USED

MICRO-CONNECTOR

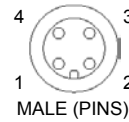

Connector Option (S14)

MICRO-CONNECTOR

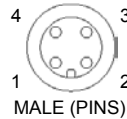

MICRO-CONNECTOR



PIN	PM9711S14XX
1	ASI +
2	NOT USED
3	ASI -
4	NOT USED
XX	XXXXXXXXXX
1	NOT USED
2	NOT USED
3	OUT 1 -
4	OUT 1 +

Prism models approved as Non-Incendive Field Wiring Apparatus:

PM9711__†*; PM97__S02_‡*; PM97__S05_‡*; PM97__S09_‡*; PM97__S13_‡*; PM97__S15_‡*

† Any Conduit/Connector option is approved for units with Pneumatic Valve Option 11 (no solenoid).

‡ Only Pneumatic Valve Option 1B or 1D is approved.

* Any Visual Indicator and Valve Size option is approved.

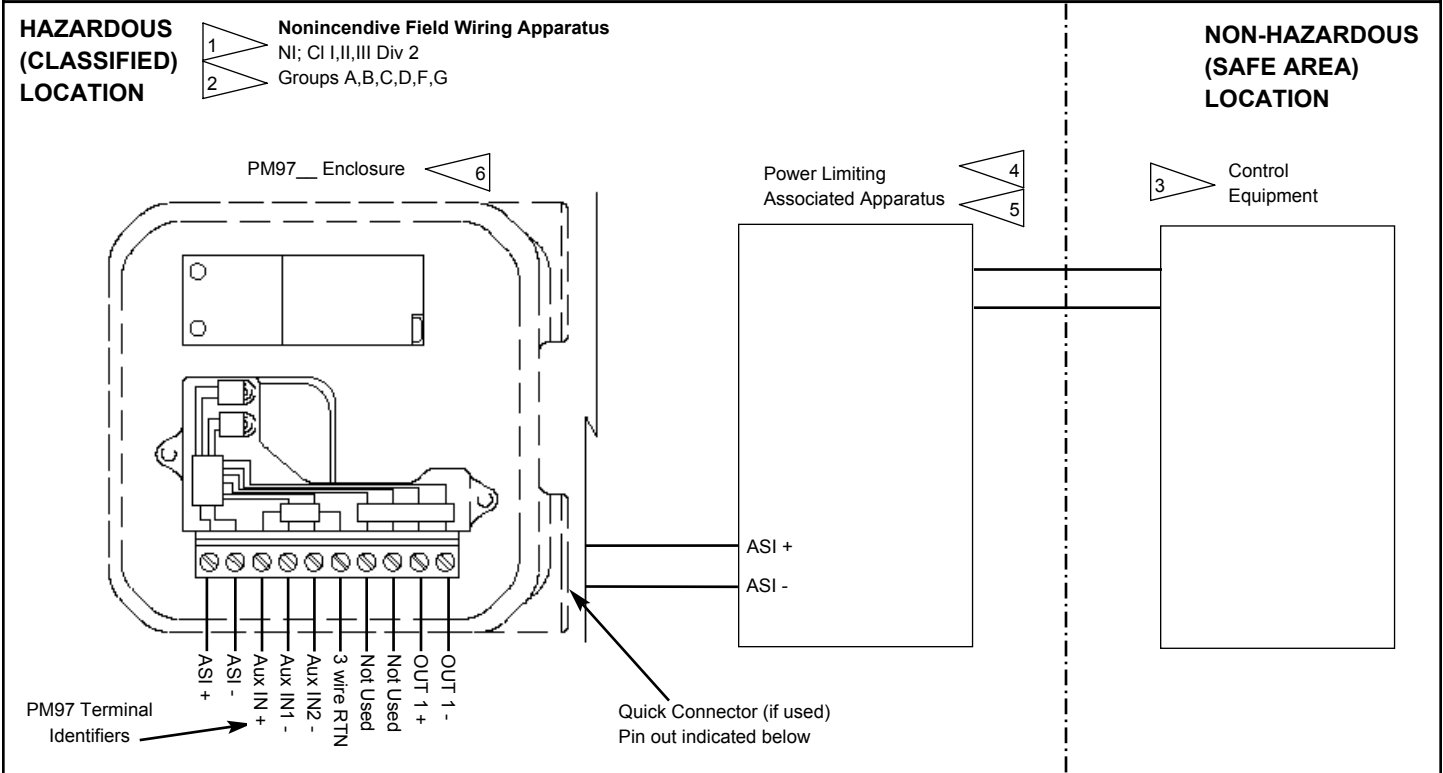

	MICRO-CONNECTOR	Pins	Signal
PM97__S13__ Pin Identifiers		1	ASI +
		2	ASI -
		3	No Connection
		4	No Connection
	MALE (PINS)		

	MICRO-CONNECTOR	Pins	Signal
PM97__S15__ Pin Identifiers		1	ASI +
		2	ASI -
		3	No Connection
		4	No Connection
		5	No Connection
	MALE (PINS)		

INSTALLATION NOTES:

Entity Parameters: PM97____: $U_i = 37 \text{ Vdc}$; $I_i = 150 \text{ mA}$; $C_i = 0.0 \text{ nF}$; $L_i = 0.0 \text{ mH}$; $P_i = 3.0 \text{ W}$

1. Installation shall be in accordance with ANSI/ISA RPA12.6.01, ANSI/NFPA 70, and the National Electrical Code.
2. Dust-tight conduit seal must be used when installed in Class II and Class III environments or where Ingress Protection of IP67 is required.
3. Control equipment must be FM approved to supply power in Class I, Division 2 Areas.
4. Power Limiting Associated Apparatus must satisfy the conditions: $V_{oc} \text{ or } V_t \leq V_i$, $I_{sc} \text{ or } I_t \leq I_i$, $C_a \geq C_i + C_{cable}$, $L_a \geq L_i + L_{cable}$ of the PM97____ Entity Parameters
5. Manufacturer's associated non-incendive field wiring apparatus installation drawing must be followed when installing this equipment.
6. Parts of the enclosure are non-conducting and may generate an ignition-capable level of electrostatic charge under certain extreme conditions. The user should ensure that the equipment is not installed in location where it may be subjected to external conditions (such as high-pressure steam) which might cause a build-up of electrostatic charge on non-conducting surfaces. Additionally, cleaning of the equipment should only be done with a damp cloth.
7. Substitution of components may impair hazardous location safety.