



# VCT module with AS-Interface Communication and Extended Addressing (SR97\_ \_ \_ \_)

## Installation & Adjusting Instructions

Publ #105135revA

### Mounting to Namur Style Actuator

1. Attach mounting plate to monitor using fasteners and lockwashers provided.
2. Align namur shaft so that it fits in the groove on the top of the actuator shaft.
3. Attach mounting plate to actuator using fasteners and lockwashers provided.
4. Operate actuator to full open and full closed positions to check for proper coupling alignment. Eccentricity of shaft must be no greater than .01" from centerline. Adjust if necessary and snug-down adjustment bolts tightly.

### Mounting to Non-Namur Actuator

1. Attach mounting plate to monitor using fasteners and lockwashers provided.
2. Remove spacer screw and attach spring torque coupler or drive block to the shaft with spacer screw or screw provided with mounting kit. Align drive block or spring torque coupler with mating shaft and lower until the mounting bracket meets its mating surface. Ensure the coupler or drive block have fully engaged the output shaft of the device to be monitored.
3. Attach mounting plate to actuator using fasteners and lockwashers provided.
4. Operate actuator to full open and full closed positions to check for proper coupling alignment. Eccentricity of shaft must be no greater than .01" from centerline. Adjust if necessary and snug-down adjustment bolts tightly.

### Visual Indicator Adjustment

5. Remove cover from unit. Lift indicator drum to disengage from splined drive. Rotate indicator until it reaches the desired position. Slide indicator drum onto splined drive to re-engage. Replace the cover.

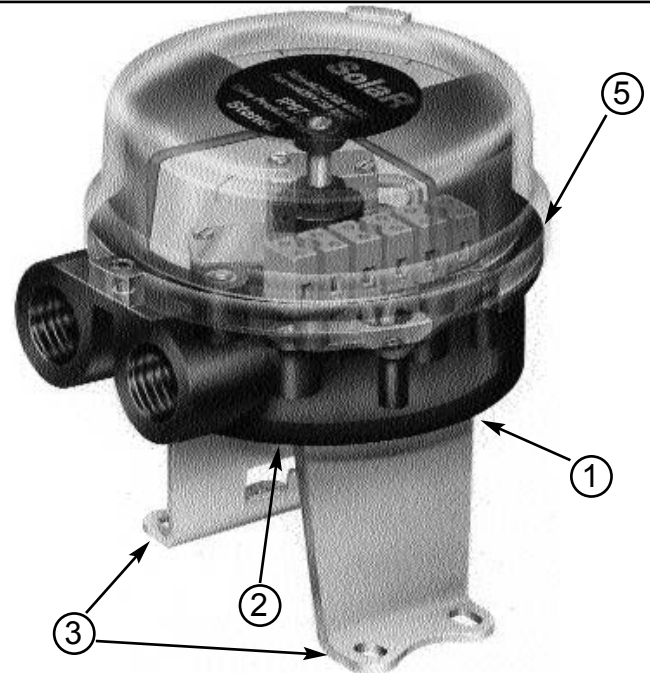

### Installing & Removing Cover

The cover goes from open to full closed with a turn of about 25 degrees.

#### Removing the Cover

- I. Loosen cover lock screw to where the bottom of the screw head is flush with top of the cover locking tab. This is the non-locking position and the way it is shipped from the factory.
- II. Remove the cover by turning it approximately 25 degrees counterclockwise until it hits the stop and lift the cover off.

#### Replacing the Cover

- I. The cover O'Ring **must** be in place on the housing body.
- II. Place the cover on the housing with the cover locking tab 25 degrees counterclockwise from the hole between the conduit entries (see diagram 1). The cover will fit properly on the housing **only** in this position.
- III. Twist the cover 25 degrees clockwise until the cover locking screw is directly over the hole between the conduit entries (see diagram 2).
- IV. To insure NEMA 4 & 4X ratings the cover **must be** completely closed and the O'Ring sealed to keep out water. This is achieved when the cover is closed and locking screw can be easily screwed in until the top of the screw head is flush with the top of the cover locking tab. Check the cover O'Ring to make sure it is in place and not buckled.

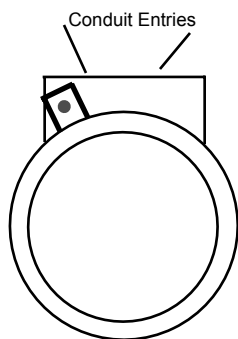

Cover Open Position Diagram 1

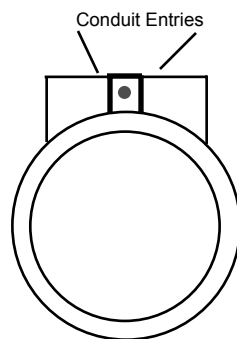

Cover Closed Diagram 2



StoneL Corporation  
One StoneL Dr  
26275 US Hwy 59  
Fergus Falls, MN 56537  
USA

Telephone: 218.739.5774  
Toll Free: 800.843.7866  
Fax: 218.739.5776  
E-mail: sales@stonel.com  
Website: www.stonel.com

## Specifications

Communication Protocol:	AS-Interface
Configuration:	(2) Discrete Inputs (Sensors) (2) Auxiliary Discrete Inputs (1) Discrete Output (Solenoid)
Voltage:	24-30 VDC (AS-i Voltage)
Output Voltage:	24 VDC
Max. Output Current:	100mA
Max. Output Power:	2.4 Watts

ID/IO Codes:	ID = A; IO = 4; ID1 = 7; ID2 = E
Default Address:	0A
Bit Assignment:	<u>Inputs</u> <u>Outputs</u>
	Bit 1 = Aux Input 1      Bit 1 = Not Used
	Bit 2 = Aux input 2      Bit 2 = Not Used
	Bit 3 = Green LED      Bit 3 = OUT 1
	Bit 4 = Red LED      Bit 4 = Not Used

## Warranty

All mechanical parts	2 years
Sensor Module	5 years

## Touch & Tune™ Switch Setting

Notes: All adjustments assume you are looking down on the top of the sensors. The edge of the cam metal strip will be at the edge of the sensor target when activation occurs. When the cam is released be sure it slides fully onto the spline. One spline tooth setting is 4 1/2°.

### I. For Normally Open Function (See Fig. 1):

6. With the valve in the "Closed" position and if the valve turns counter-clockwise to open, set both cams so that the metal activation strips are 180° from each other with the bottom cam set in the middle of the sensor target.
- 6a. Lift the bottom cam and turn counter-clockwise until the red LED goes "out" then clockwise again until the red LED just comes "on". (Reverse the direction of the cam if the valve opens clockwise.)
- 6b. Move the valve to the opposite position (Open), push down on the top cam and rotate counter-clockwise until the green LED just comes "on". (Reverse the direction of the cam if the valve opens clockwise.)

*For the normally open operation, both LEDs will be off during the actuation period. If the optional green "Closed" visual indicator is used the colors would be reversed in steps 6 and 7.*

### II. For Normally Closed Function (See Fig. 2):

7. With the valve in the closed position, set both cams so that the metal activation strips are aligned with each other and set in the middle of the sensor targets.
- 7a. If the valve turns counter-clockwise to open, pull up on the bottom cam and rotate clockwise until the red LED goes "out". (If the valve turns clockwise to open, rotate bottom cam counter-clockwise until it goes out.)
- 7b. Operate the valve to the opposite position (Open). Push down on the top cam. If the green LED is "off", rotate top cam clockwise until it comes "on". When the green LED is "on" turn cam counter-clockwise until the green LED just goes "off".

*For the normally closed operation, both the red and green LEDs will be illuminated during the actuation period. The red LED is off in the "Closed" position and the green LED is off in the "Open" position. If the optional green "Closed" visual indicator is used the colors would be reversed in steps 6 and 7.*

**To Bench Test AS-Interface Module:** Use 24 VDC power supply across ASI + and ASI -. No series resistor needed. To test communication, a functioning AS-Interface network is required.

**Do not apply external power to output terminals**

## Wiring Diagram

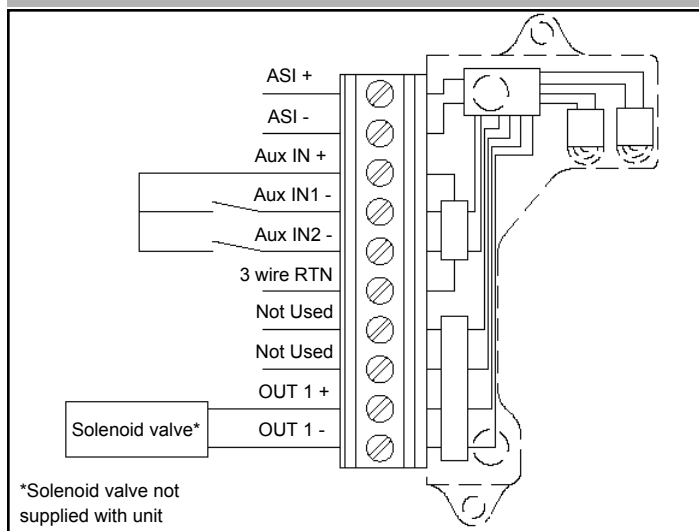

## Sensor Settings

**Cams Set for Normally Open Sensor Function**

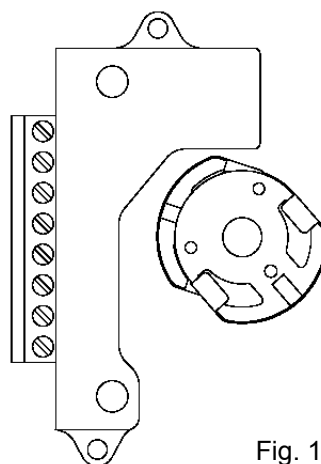

Fig. 1

**Cams Set for Normally Closed Sensor Function**

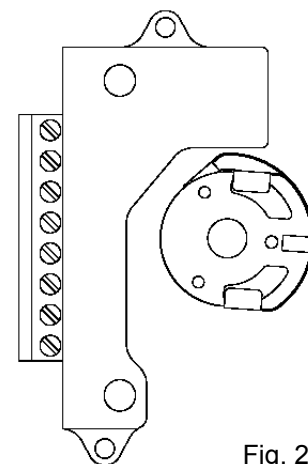

Fig. 2