

# Axiom<sup>®</sup>

with SST™ Sensing & Communications Module  
(AMI33\_\_\_\_\_)

## Installation & Adjusting Instructions

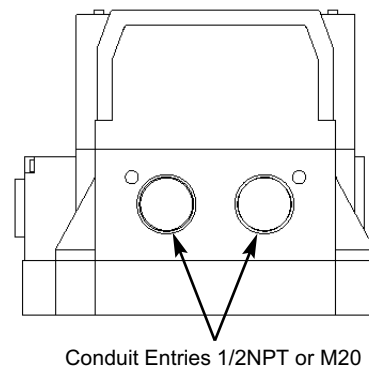
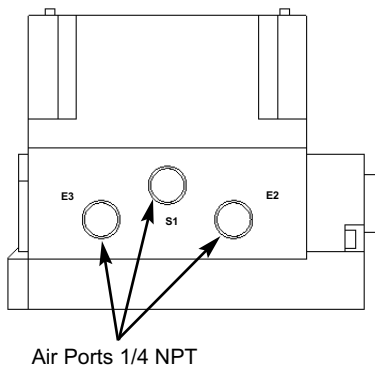
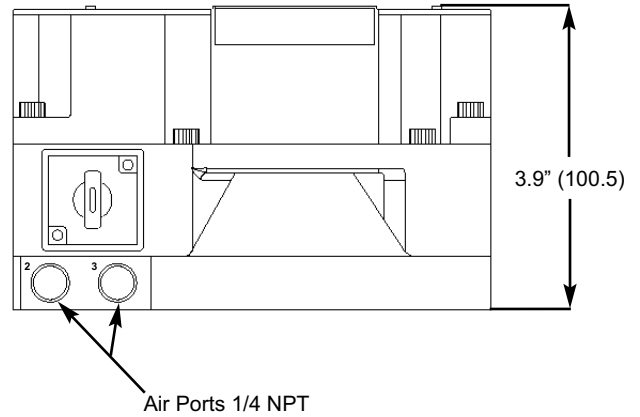
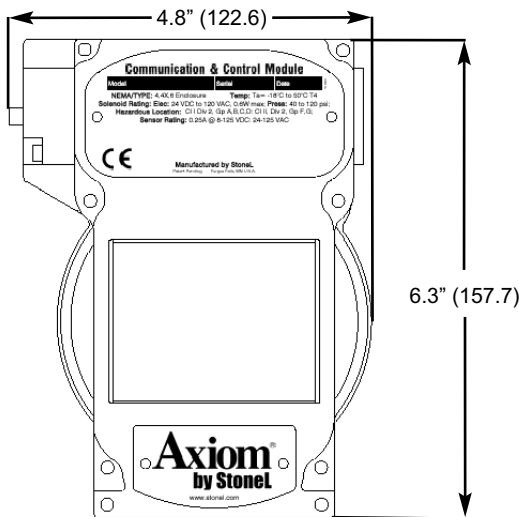
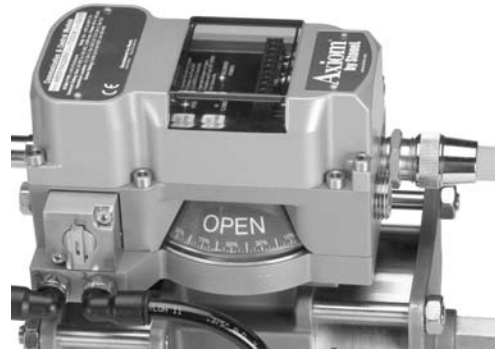

Stonel Corporation  
One StoneL Dr  
26275 US Hwy 59  
Fergus Falls, MN 56537 USA  
Telephone: 218.739.5774  
Toll Free: 800.843.7866  
Fax: 218.739.5776  
E-mail: sales@stonel.com  
Website: www.stonel.com

## Axiom Model Selector (Example: AMI333HA11SRA)

	Function	Pneumatic Valve	Approvals	Entry Options	Capabilities	Visual Indicator	Brand	Options
<b>AMI</b>	<b>Sensor Modules</b> <b>33</b> (2) SST N.O. Sensors <b>34</b> (2) SST N.C. Sensors	<b>Single Solenoid Spring Return</b> <b>1H</b> 24VDC/120VAC Universal <i>(Use with Function 33 or 34 only)</i> <b>Dual Solenoid Shuttle Piston</b> <b>2H</b> 24VDC/120VAC Universal <i>(Use with Function 33 or 34 only)</i> <b>Single Solenoid Spring Return</b> <b>(Momentary Ext. Manual Override)</b> <b>3H</b> 24VDC/120VAC Universal <i>(Use with Function 33 or 34 only)</i> <b>Dual Solenoid Shuttle Piston</b> <b>(Momentary Ext. Manual Override)</b> <b>4H</b> 24VDC/120VAC Universal <i>(Use with Function 33 or 34 only)</i> <b>Single Solenoid Spring Return</b> <b>(Latching Ext. Manual Override)</b> <b>5H</b> 24VDC/120VAC Universal <i>(Use with Function 33 or 34 only)</i> <b>Dual Solenoid Shuttle Piston</b> <b>(Latching Ext. Manual Override)</b> <b>6H</b> 24VDC/120VAC Universal <i>(Use with Function 33 or 34 only)</i>	<b>A</b> cFMus <b>V</b> ATEX <b>L</b> Inmetro	<b>02</b> (2) 1/2" NPT <b>05</b> (2) M20 <b>10</b> (1) 4-Pin Mini Connector <b>11</b> (1) 5-Pin Mini Connector <b>13</b> (1) 4-Pin Micro Connector <b>15</b> (1) 5-Pin Micro Connector <b>17</b> (1) 6-Pin Micro Connector <b>18</b> (1) 8-Pin Micro Connector <b>19</b> (1) 6-Pin Mini Connector <b>20</b> (1) 7-Pin Mini Connector <b>21</b> (1) 8-Pin Mini Connector	<b>S</b> Standard <b>D</b> Diagnostics <i>(Function 96 only)</i>	<b>R</b> Red Closed <b>G</b> Green Closed <b>1</b> T1 Three Way <b>2</b> T2 Three Way <b>X</b> Special	<b>A</b> StoneL <b>M</b> Metso <b>N</b> Neles	<b>-XXXXX</b> Special Unit ID <b>-T</b> Extended Temp. Coil

## SST Switching Sensors(33)

Sensors: (2) NO 2-wire Solid State Sensors  
 Voltage Range: 20 to 125 VDC (max 75vdc for "Ex n" apps)  
 110 to 125 VAC (not applicable for "Ex n" apps)  
 Max Current Continuous: 0.25 Amps

Minimum On Current: 2.0 mA  
 Max Leakage Current: 0.5 mA  
 Max Voltage Drop: 7.0 Volts @ 100mA  
 Circuit Protection: Protected against short circuits and direct application of voltage with no load.

### To Bench Test a SST Sensing & Communications Module:

Power must be applied to both sensors to ensure proper circuit operation. Use a 24 Vdc power supply with series load resistor, (2K - 6K  $\Omega$ ), connected to the 24 Vdc+. Operate actuator to the closed position. Connect 24 Vdc+ to the "Closed C" (common) and "Open C" (common) terminals. Connect 24 Vdc- to the "Closed NO" and "Open NO" terminals. Press and hold "Closed Set" button until "Closed LED is lit (2 seconds). Release button. Operate actuator to the open position. Press and hold "Open Set" button until "Open LED is lit (2 seconds). Release button. Set points are retained even after power is removed.

To test solenoid, apply power to the "Sol Pwr IN" terminals only. See warning below.

#### WARNING:

**DO NOT APPLY EXTERNAL POWER TO THE "Sol Out" TERMINALS. THIS WILL CAUSE PERMANENT DAMAGE TO THE UNIT**

#### CAUTION

**A SERIES LOAD RESISTOR MUST BE USED WHEN BENCH TESTING IN ORDER TO ENSURE PROPER MODULE OPERATION**

#### NOTE

**IF USING ONLY ONE OF THE SENSORS FOR VALVE POSITION FEEDBACK, THE OPEN SENSOR (GREEN) MUST BE USED**

## Wiring Diagram and Standard Connector Configuration Pin-Out

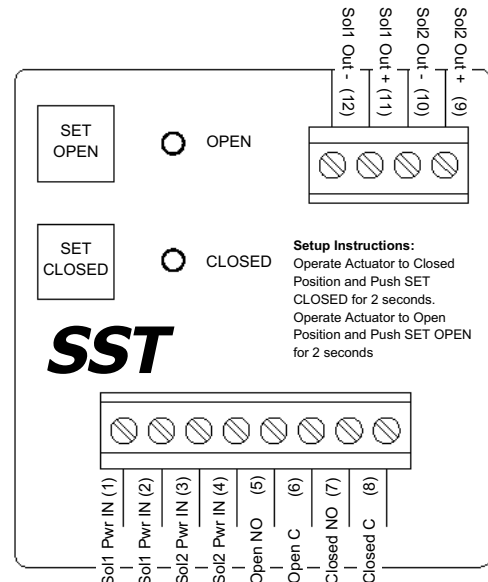
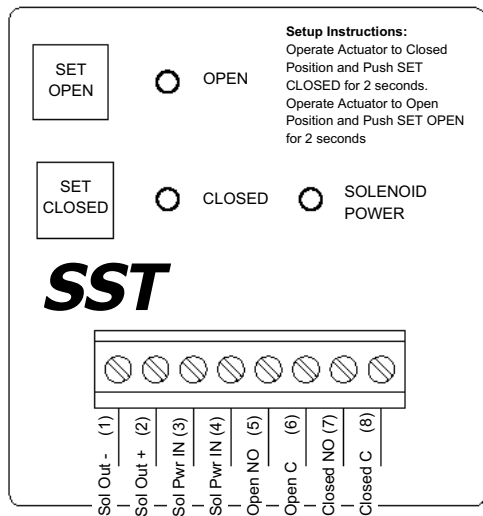

5-PIN MICRO-CONNECTOR

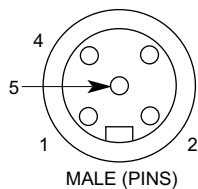

PIN	SIGNAL
1	OPEN/CLOSED C
2	CLOSED NO
3	OPEN NO
4	SOL PWR IN +
5	SOL PWR IN -

5-PIN MINI-CONNECTOR

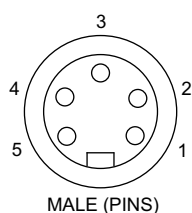

6-PIN MICRO-CONNECTOR

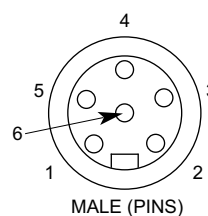

6-PIN MINI-CONNECTOR

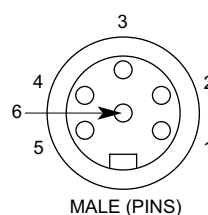

PIN	SIGNAL
1	OPEN/CLOSED C
2	CLOSED NO
3	OPEN NO
4	SOL1&SOL2 PWR IN
5	SOL1 PWR IN
6	SOL2 PWR IN

### Materials of Construction

Cover: Lexan® Polycarbonate  
 Housing: Epoxy Coated Anodized Aluminum  
 Fasteners: Stainless Steel  
 O-Rings: Nitrile compound  
 Valve Manifold: Epoxy Coated Anodized Aluminum  
 Operating Life: One Million Cycles  
 Temperature Range: See Solenoid Specifications

### Enclosure Protection

NEMA: 4, 4X, 6; IP67

### Hazardous Location Ratings

Nonincendive: Class I&II, Div 2, All Gas Groups

### Warranty

Sensing & Communication Module: Five Years  
 Mechanical Components: Two Years

## Pneumatic Valve Specifications

### General Pneumatic Specifications

Valve Design: Pilot operated spool valve  
 Pilot Operator Options: Solenoid Coil or Piezo  
 Configuration:  
   Single Pilot: 5-Way, 2-Position, Spring Return  
   Dual Pilot: 5-Way, 2-Position, Shuttle Piston  
 Flow Rating: 0.70 Cv (Kv = 0.60 based on flow m3/h)  
 Porting: 1/4" NPT  
 Operating Pressure: 40 psi to 120 psi (2.7 to 7.5 bar)  
 Filtration Requirements: 40 Microns  
 Operating Temperature: See pilot specifications  
 Operating Life: 1 million cycles  
 Manual Override: Internal momentary  
 Material of Construction:  
   Spool: Anodized aluminum  
   Body: Epoxy coated anodized aluminum  
   O-ring Spacers: Polysulphone  
   End Caps & Fasteners: Stainless Steel  
   O-rings: A Nitrile Compound

### Solenoid Coil Specifications

**24 VDC/120 VAC Universal (1H, 2H, 3H, 4H, 5H, 6H)**  
 Operating Voltage: 22 VDC min/130 VAC max  
 Power Consumption: 0.6 Watts  
 AC Current Consumption: 18mA  
 Operating Temperature: -18° C to 50° C (0° F to 120° F)  
 Extended Temp (-T option) -40° C to 80° C (-40° F to 176° F) (NEC)  
   -40° C to 70° C (-40° F to 158° F) (IEC)  
 Filtration Requirements: 40 Microns

### 24 VDC (1B, 2B, 3B, 4B, 5B, 6B)

Operating Voltage: 24 VDC  
 Power Consumption: 1.8 Watts  
 Operating Temperature: -18° C to 50° C (0° F to 120° F)  
 Extended Temp (-T option) -40° C to 80° C (-40° F to 176° F) (NEC)  
   -40° C to 70° C (-40° F to 158° F) (IEC)  
 Filtration Requirements: 40 Microns

### 24 VDC (1D, 2D, 3D, 4D, 5D, 6D)

Operating Voltage: 24 VDC  
 Power Consumption: 0.5 Watts  
 Operating Temperature: -18° C to 50° C (0° F to 120° F)  
 Extended Temp (-T option) -40° C to 80° C (-40° F to 176° F) (NEC)  
   -40° C to 70° C (-40° F to 158° F) (IEC)  
 Filtration Requirements: 40 Microns

### 12 VDC (1E, 2E, 3E, 4E, 5E, 6E) (Intrinsically Safe)

Operating Voltage: 12 VDC (output of barrier)  
 Power Consumption: 0.5 Watts  
 Operating Temperature: -18° C to 50° C (0° F to 120° F)  
 Extended Temp (-T option) -40° C to 80° C (-40° F to 176° F) (NEC)  
   -40° C to 70° C (-40° F to 158° F) (IEC)  
 Filtration Requirements: 40 Microns  
 Entity Parameters: Ui=28VDC; Ii=120mA; Ci=0; Li=0; Pi=1.0W

### Piezo (1A, 2A, 3A, 4A, 5A, 6A)

Operating Voltage: 5.5 VDC to 9.0 VDC  
 Current Consumption: 2.0 mA @ 6.5 VDC  
 Temperature Range: -10° C to 60° C (14° F to 140° F)  
 Filtration Requirements: Dried/30 Microns

**Spring Return Actuator with Rebreather Open**

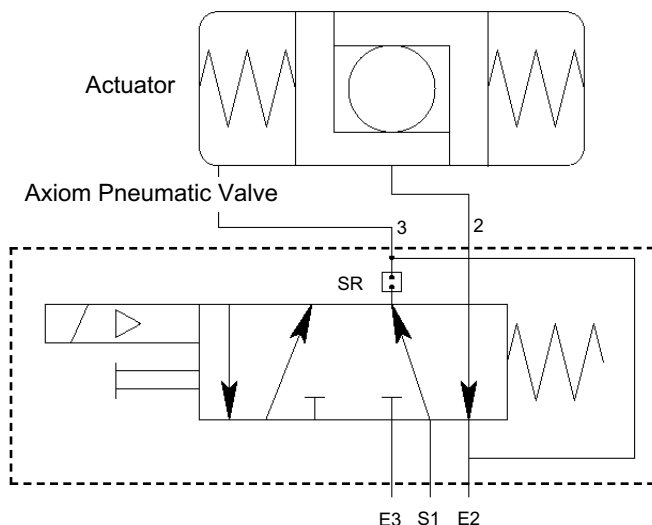

**Double Acting Actuator with Rebreather Closed**

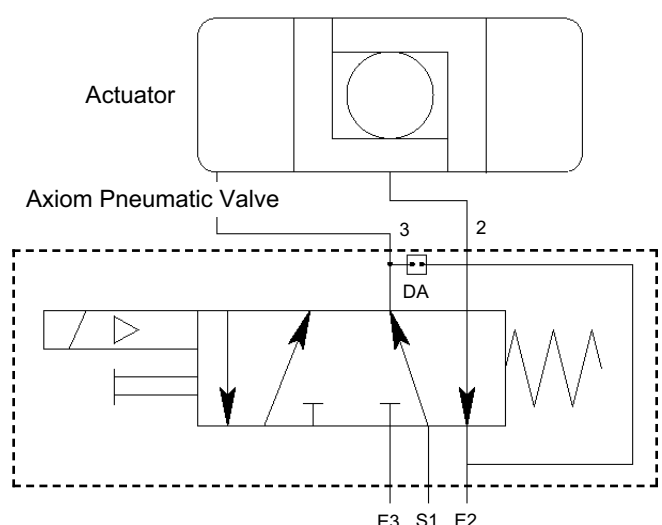

**Note**

Mounting of the Axiom requires a StoneL mounting kit specific to the actuator the Axiom is to be mounted to.

**Note**

It is recommended that thread lubricant or anti-seize be used on the Axiom Cover Screws (Item# 1) and Axiom Body Screws (Item# 3) prior to assembly.

**Note**

In high cycle or high vibration applications, blue Loctite® may be used on the Air Manifold Mounting Screws (Item# 11) and the Visual Indicator Drum Retaining Screw (Item# 9).

**Note**

It is highly recommended that exhaust ports E2 and E3 be fitted with low restriction mufflers or breather vent caps to prevent ingestion of water and debris into the pneumatic valve .

1. Refer to Axiom Assembly Drawing located on Page 6 when performing mounting and assembly procedures.
2. Remove Axiom unit from shipping container. Ensure all listed items are present.
3. With an M4 allen wrench, loosen the four captive Axiom Cover Screws (Item# 1), remove cover.
4. Determine if the actuator the Axiom is to be mounted on is double acting (DA) or spring return (SR). Flip the Axiom body (Item# 4) over and ensure the DA/SR Plug (Item# 5) is in the correct position. (See Detail - A on Page 6). If the DA/SR Plug is in the incorrect position, gently remove plug with a pair of pliers and insert into the proper hole.
5. From the mounting kit package, locate the Air Manifold Plate (Item# 14). Place the Air Manifold Plate on the actuator. Using an M4 allen wrench, fasten down with the four Air Manifold Mounting Screws (Item# 11). Torque screws to 25 - 30 in.lbs (2.8 - 3.4Nm).
6. Place Visual Indicator Drive Block (Item# 10) into slot on the actuator shaft. Place Visual Indicator Drum Coupler (Item# 8) onto the Visual Indicator Drive Block. Next, place the Visual Indicator Drum (Item# 7) onto the Visual Indicator Drum Coupler. Align the holes in all three items with the the threaded hole in the actuator shaft and fasten down with the Visual Indicator Drum Retaining Screw (Item# 9). Leave screw loose in order to facilitate indexing of the visual indicator.
7. With the actuator in the closed position, center the Visual Indicator Drum until the "OPEN" quadrant is centered between the "V.I INDEX" markings on the Air Manifold Plate. (See Detail - B on Page 6). Tighten down with the Visual Indicator Drum Retaining Screw 15 - 20 in.lbs (1.7 - 2.3Nm).
8. Verify Air Manifold Plate Orifice O-rings (Item# 12) and Visual Indicator Cover O-ring (Item# 13) are in place.
9. Place the Visual Indicator Cover (Item# 6) over the Visual Indicator Drum assembly then set the Axiom Body (Item# 4) in place. With an M4 allen wrench, torque the Axiom Body Screws (Item# 3) to 25 - 30 in.lbs (2.8 - 3.4Nm).
10. After all wiring and sensor setting procedures have been completed, install Axiom Cover and torque Axiom Cover Screws to 15 - 20 in.lbs (1.7 - 2.3Nm).

## Sensing & Communications Module Sensor Setting Instructions

1. With the Sensor & Communication Module (CCM) wired to the control system and power applied, (Refer Wiring Diagram located on Page 4), operate actuator to the closed position.
2. Press and hold "Closed Set" button until "Closed LED is lit (2 seconds). Release button.
3. Operate actuator to the open position.
4. Press and hold "Open Set" button until "Open LED is lit (2 seconds). Release button.
5. Set points are retained even after power is removed.
6. Sensor & Communication Modules on Axiom units with a single solenoid have a "Solenoid Power" LED indicating when solenoid power is applied.

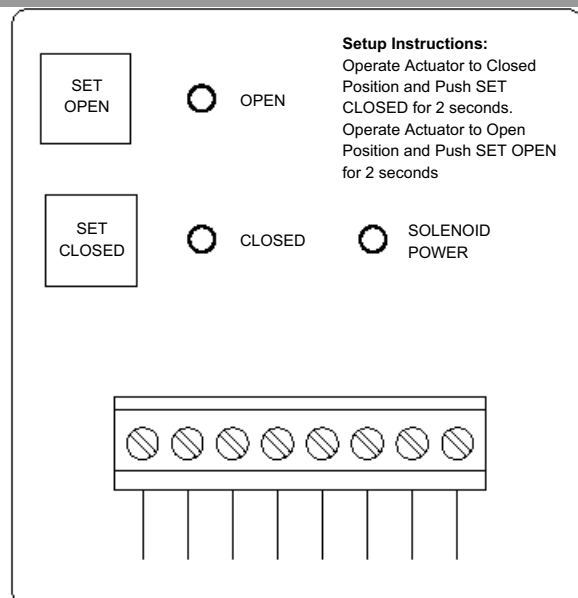

# Axiom Assembly Drawing

ITEM#	DESCRIPTION	QTY
1	Axiom Cover Screws	4
2	Axiom Cover	1
3	Axiom Body Screws	4
4	Axiom Body	1
5	DA/SR Plug	1
6	Visual Indicator Cover	1
7	Visual Indicator Drum	1
8	Visual Indicator Drum Coupler	1

Item# 9 thru 14 are provided with the mounting kit.  
Mounting kits are sold separately

9	Visual Indicator Drum Retaining Screw	1
10	Visual Indicator Drive Block	1
11	Air Manifold Plate Mounting Screws	4
12	Air Manifold Plate Orifice O-rings	3
13	Visual Indicator Cover O-ring	1
14	Air Manifold Plate	1

