

with  **AS-Interface**
Axiom[®] Sensing & Communications Module (Extended Addressing)
 (AMI97_____)

Installation & Adjusting Instructions

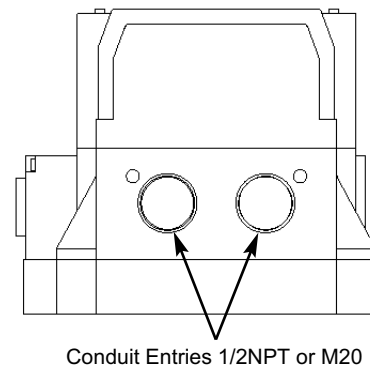
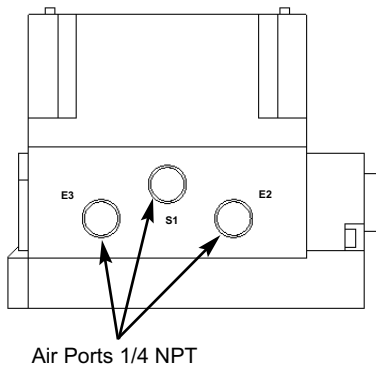
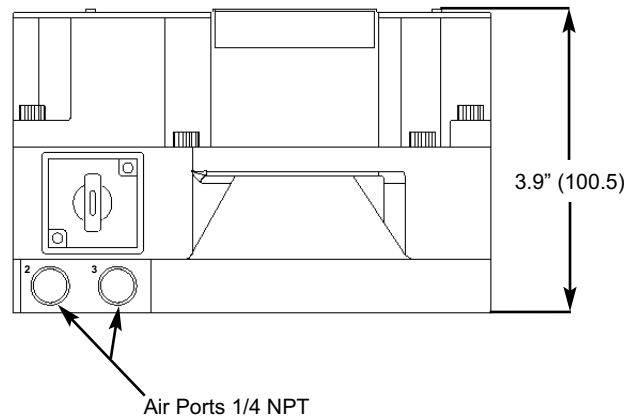
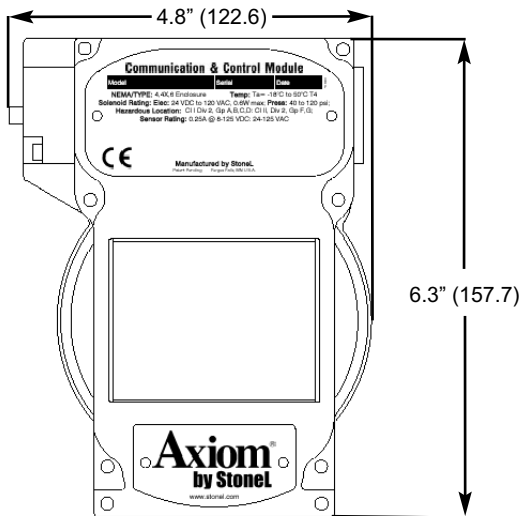
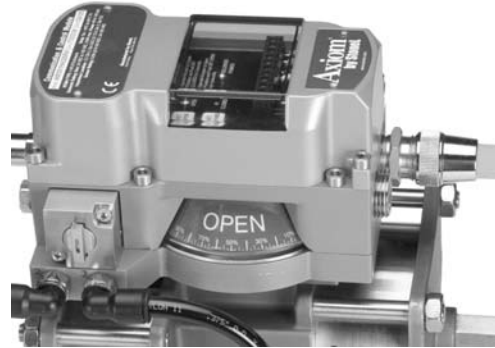

Stonel Corporation
 One StoneL Dr
 26275 US Hwy 59
 Fergus Falls, MN 56537 USA
 Telephone: 218.739.5774
 Toll Free: 800.843.7866
 Fax: 218.739.5776
 E-mail: sales@stonel.com
 Website: www.stonel.com

Axiom Model Selector (Example: AMI975DA13SRA)

	Function	Pneumatic Valve	Approvals	Entry Options	Capabilities	Visual Indicator	Brand	Options
AMI	Bus Communication Modules 97 AS-Interface <i>(with Extended Addressing)</i>	Single Solenoid Spring Return 1B 24VDC/1.8 watt coil <i>(Use with Function 92, 94, 95, 96, 97)</i> 1D 24VDC/0.5 watt coil <i>(Use with Function 92, 94, 95, 96, 97)</i> Single Solenoid Spring Return (Momentary Ext. Manual Override) 3B 24VDC/1.8 watt coil <i>(Use with Function 92, 94, 95, 96, 97)</i> 3D 24VDC/0.5 watt coil <i>(Use with Function 92, 94, 95, 96, 97)</i> Single Solenoid Spring Return (Latching Ext. Manual Override) 5B 24VDC/1.8 watt coil <i>(Use with Function 92, 94, 95, 96, 97)</i> 5D 24VDC/0.5 watt coil <i>(Use with Function 92, 94, 95, 96, 97)</i>	A cFMus V ATEX L Inmetro	02 (2) 1/2" NPT 05 (2) M20 10 (1) 4-Pin Mini Connector 11 (1) 5-Pin Mini Connector 13 (1) 4-Pin Micro Connector 15 (1) 5-Pin Micro Connector 17 (1) 6-Pin Micro Connector 18 (1) 8-Pin Micro Connector 19 (1) 6-Pin Mini Connector 20 (1) 7-Pin Mini Connector 21 (1) 8-Pin Mini Connector	S Standard D Diagnostics <i>(Function 96 only)</i>	R Red Closed G Green Closed 1 T1 Three Way 2 T2 Three Way X Special	A StoneL M Metso N Neles	-XXXXX Special Unit ID -T Extended Temp. Coil

AS-Interface Module Specifications

Communication Protocol: AS-Interface
 Configuration: (2) Discrete Inputs (Sensors)
 (2) Auxiliary Discrete Inputs
 (1) Discrete Output (Solenoid)
 Voltage: 26.5-30.6 VDC (AS-I Voltage)
 Output Voltage: 24 VDC
 Current Consumption: 42mA (0.5w coil); 96mA (1.8w coil)
 Max. Output Current: 100mA

ID/IO Codes: ID = A; IO = 4; ID1 = F; ID2 = E
 Default Address: 0A
 Bit Assignment:

Inputs	Outputs
Bit 1 = Aux Input 1	Bit 1 = Not Used
Bit 2 = Aux input 2	Bit 2 = Not Used
Bit 3 = Green LED	Bit 3 = OUT 1
Bit 4 = Red LED	Bit 4 = Not Used

To Bench Test an AS-Interface Sensing & Communications Module:

To test sensors, use a 24 Vdc power supply. No series load resistor is required. Operate actuator to the closed position. Apply power across the "ASI+" and "ASI-" terminal points. Press and hold "Closed Set" button until "Closed LED is lit (2 seconds). Release button. Operate actuator to the open position. Press and hold "Open Set" button until "Open LED is lit (2 seconds). Release button. Set points are retained even after power is removed. A functioning AS-Interface network is required to test communications.

WARNING:

DO NOT APPLY EXTERNAL POWER TO THE OUTPUT TERMINALS. THIS WILL CAUSE PERMANENT DAMAGE TO THE UNIT

Wiring Diagram and Standard Connector Configuration Pin-Out

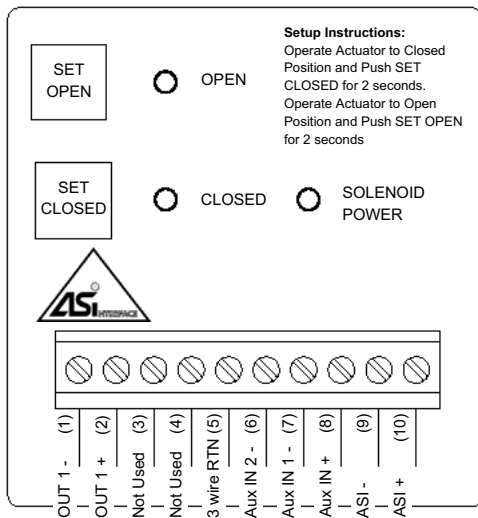

4-PIN MICRO-CONNECTOR

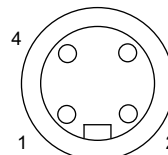

MALE (PINS)

4-PIN MINI-CONNECTOR

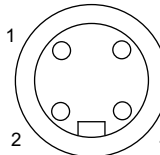

MALE (PINS)

PIN	SIGNAL
1	ASI+
2	Not Used
3	ASI-
4	Not Used

Materials of Construction

Cover: Lexan® Polycarbonate
 Housing: Epoxy Coated Anodized Aluminum
 Fasteners: Stainless Steel
 O-Rings: Nitrile compound
 Valve Manifold: Epoxy Coated Anodized Aluminum
 Operating Life: One Million Cycles
 Temperature Range: See Solenoid Specifications

Enclosure Protection

NEMA: 4, 4X, 6; IP67

Hazardous Location Ratings

Nonincendive: Class I&II, Div 2, All Gas Groups

Warranty

Sensing & Communication Module: Five Years
 Mechanical Components: Two Years

Pneumatic Valve Specifications

General Pneumatic Specifications

Valve Design: Pilot operated spool valve
 Pilot Operator Options: Solenoid Coil or Piezo
 Configuration:
 Single Pilot: 5-Way, 2-Position, Spring Return
 Dual Pilot: 5-Way, 2-Position, Shuttle Piston
 Flow Rating: 0.70 Cv (Kv = 0.60 based on flow m3/h)
 Porting: 1/4" NPT
 Operating Pressure: 40 psi to 120 psi (2.7 to 7.5 bar)
 Filtration Requirements: 40 Microns
 Operating Temperature: See pilot specifications
 Operating Life: 1 million cycles
 Manual Override: Internal momentary
 Material of Construction:
 Spool: Anodized aluminum
 Body: Epoxy coated anodized aluminum
 O-ring Spacers: Polysulphone
 End Caps & Fasteners: Stainless Steel
 O-rings: A Nitrile Compound

Solenoid Coil Specifications

24 VDC/120 VAC Universal (1H, 2H, 3H, 4H, 5H, 6H)
 Operating Voltage: 22 VDC min/130 VAC max
 Power Consumption: 0.6 Watts
 AC Current Consumption: 18mA
 Operating Temperature: -18° C to 50° C (0° F to 120° F)
 Extended Temp (-T option) -40° C to 80° C (-40° F to 176° F) (NEC)
 -40° C to 70° C (-40° F to 158° F) (IEC)
 Filtration Requirements: 40 Microns

24 VDC (1B, 2B, 3B, 4B, 5B, 6B)

Operating Voltage: 24 VDC
 Power Consumption: 1.8 Watts
 Operating Temperature: -18° C to 50° C (0° F to 120° F)
 Extended Temp (-T option) -40° C to 80° C (-40° F to 176° F) (NEC)
 -40° C to 70° C (-40° F to 158° F) (IEC)
 Filtration Requirements: 40 Microns

24 VDC (1D, 2D, 3D, 4D, 5D, 6D)

Operating Voltage: 24 VDC
 Power Consumption: 0.5 Watts
 Operating Temperature: -18° C to 50° C (0° F to 120° F)
 Extended Temp (-T option) -40° C to 80° C (-40° F to 176° F) (NEC)
 -40° C to 70° C (-40° F to 158° F) (IEC)
 Filtration Requirements: 40 Microns

12 VDC (1E, 2E, 3E, 4E, 5E, 6E) (Intrinsically Safe)

Operating Voltage: 12 VDC (output of barrier)
 Power Consumption: 0.5 Watts
 Operating Temperature: -18° C to 50° C (0° F to 120° F)
 Extended Temp (-T option) -40° C to 80° C (-40° F to 176° F) (NEC)
 -40° C to 70° C (-40° F to 158° F) (IEC)
 Filtration Requirements: 40 Microns

Entity Parameters: Ui=28VDC; Ii=120mA; Ci=0; Li=0; Pi=1.0W

Piezo (1A, 2A, 3A, 4A, 5A, 6A)

Operating Voltage: 5.5 VDC to 9.0 VDC
 Current Consumption: 2.0 mA @ 6.5 VDC
 Temperature Range: -10° C to 60° C (14° F to 140° F)
 Filtration Requirements: Dried/30 Microns

Spring Return Actuator with Rebreather Open

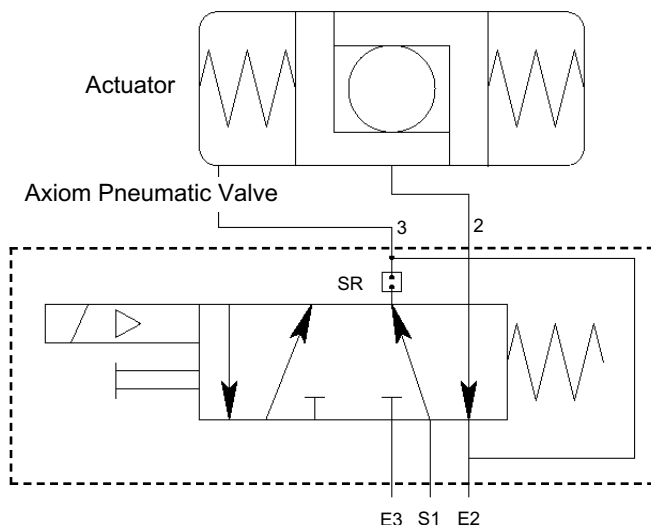

Double Acting Actuator with Rebreather Closed

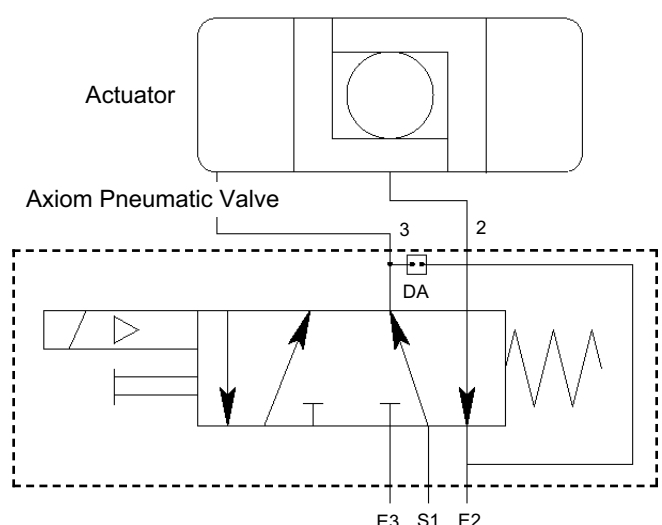

Note

Mounting of the Axiom requires a StoneL mounting kit specific to the actuator the Axiom is to be mounted to.

Note

It is recommended that thread lubricant or anti-seize be used on the Axiom Cover Screws (Item# 1) and Axiom Body Screws (Item# 3) prior to assembly.

Note

In high cycle or high vibration applications, blue Loctite® may be used on the Air Manifold Mounting Screws (Item# 11) and the Visual Indicator Drum Retaining Screw (Item# 9).

Note

It is highly recommended that exhaust ports E2 and E3 be fitted with low restriction mufflers or breather vent caps to prevent ingestion of water and debris into the pneumatic valve .

1. Refer to Axiom Assembly Drawing located on Page 6 when performing mounting and assembly procedures.
2. Remove Axiom unit from shipping container. Ensure all listed items are present.
3. With an M4 allen wrench, loosen the four captive Axiom Cover Screws (Item# 1), remove cover.
4. Determine if the actuator the Axiom is to be mounted on is double acting (DA) or spring return (SR). Flip the Axiom body (Item# 4) over and ensure the DA/SR Plug (Item# 5) is in the correct position. (See Detail - A on Page 6). If the DA/SR Plug is in the incorrect position, gently remove plug with a pair of pliers and insert into the proper hole.
5. From the mounting kit package, locate the Air Manifold Plate (Item# 14). Place the Air Manifold Plate on the actuator. Using an M4 allen wrench, fasten down with the four Air Manifold Mounting Screws (Item# 11). Torque screws to 25 - 30 in.lbs (2.8 - 3.4Nm).
6. Place Visual Indicator Drive Block (Item# 10) into slot on the actuator shaft. Place Visual Indicator Drum Coupler (Item# 8) onto the Visual Indicator Drive Block. Next, place the Visual Indicator Drum (Item# 7) onto the Visual Indicator Drum Coupler. Align the holes in all three items with the the threaded hole in the actuator shaft and fasten down with the Visual Indicator Drum Retaining Screw (Item# 9). Leave screw loose in order to facilitate indexing of the visual indicator.
7. With the actuator in the closed position, center the Visual Indicator Drum until the "OPEN" quadrant is centered between the "V.I INDEX" markings on the Air Manifold Plate. (See Detail - B on Page 6). Tighten down with the Visual Indicator Drum Retaining Screw 15 - 20 in.lbs (1.7 - 2.3Nm).
8. Verify Air Manifold Plate Orifice O-rings (Item# 12) and Visual Indicator Cover O-ring (Item# 13) are in place.
9. Place the Visual Indicator Cover (Item# 6) over the Visual Indicator Drum assembly then set the Axiom Body (Item# 4) in place. With an M4 allen wrench, torque the Axiom Body Screws (Item# 3) to 25 - 30 in.lbs (2.8 - 3.4Nm).
10. After all wiring and sensor setting procedures have been completed, install Axiom Cover and torque Axiom Cover Screws to 15 - 20 in.lbs (1.7 - 2.3Nm).

Sensing & Communications Module Sensor Setting Instructions

1. With the Sensor & Communication Module (CCM) wired to the control system and power applied, (Refer Wiring Diagram located on Page 4), operate actuator to the closed position.
2. Press and hold "Closed Set" button until "Closed LED is lit (2 seconds). Release button.
3. Operate actuator to the open position.
4. Press and hold "Open Set" button until "Open LED is lit (2 seconds). Release button.
5. Set points are retained even after power is removed.
6. Sensor & Communication Modules on Axiom units with a single solenoid have a "Solenoid Power" LED indicating when solenoid power is applied.

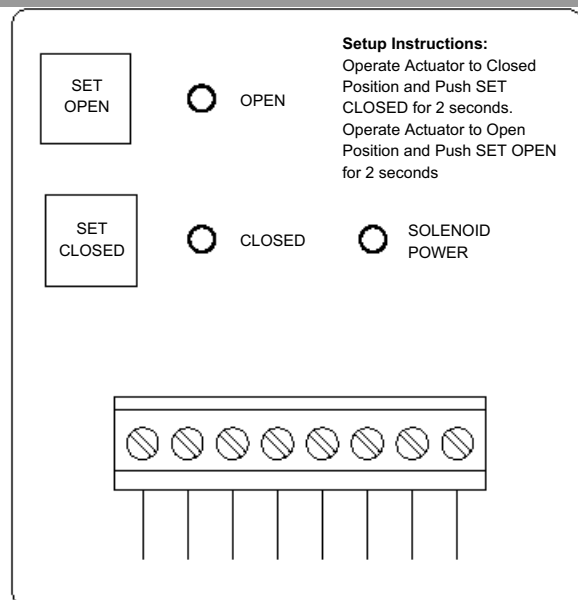

Axiom Assembly Drawing

ITEM#	DESCRIPTION	QTY
1	Axiom Cover Screws	4
2	Axiom Cover	1
3	Axiom Body Screws	4
4	Axiom Body	1
5	DA/SR Plug	1
6	Visual Indicator Cover	1
7	Visual Indicator Drum	1
8	Visual Indicator Drum Coupler	1

Item# 9 thru 14 are provided with the mounting kit.
Mounting kits are sold separately

9	Visual Indicator Drum Retaining Screw	1
10	Visual Indicator Drive Block	1
11	Air Manifold Plate Mounting Screws	4
12	Air Manifold Plate Orifice O-rings	3
13	Visual Indicator Cover O-ring	1
14	Air Manifold Plate	1

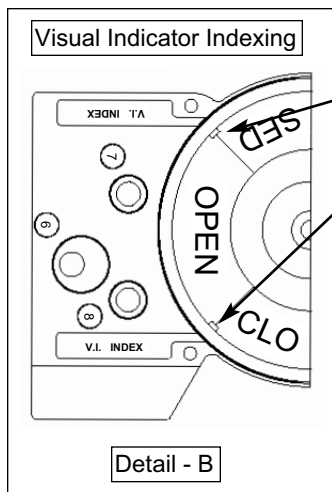
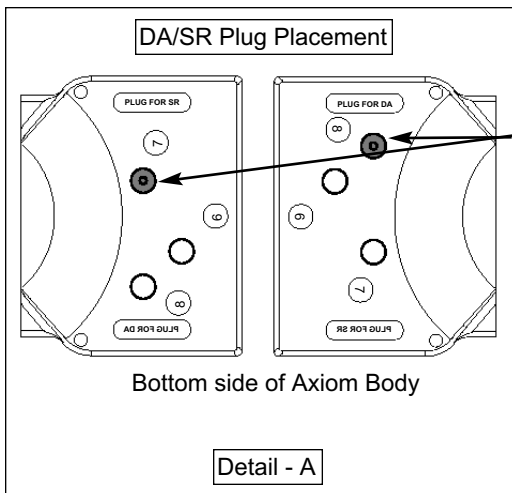
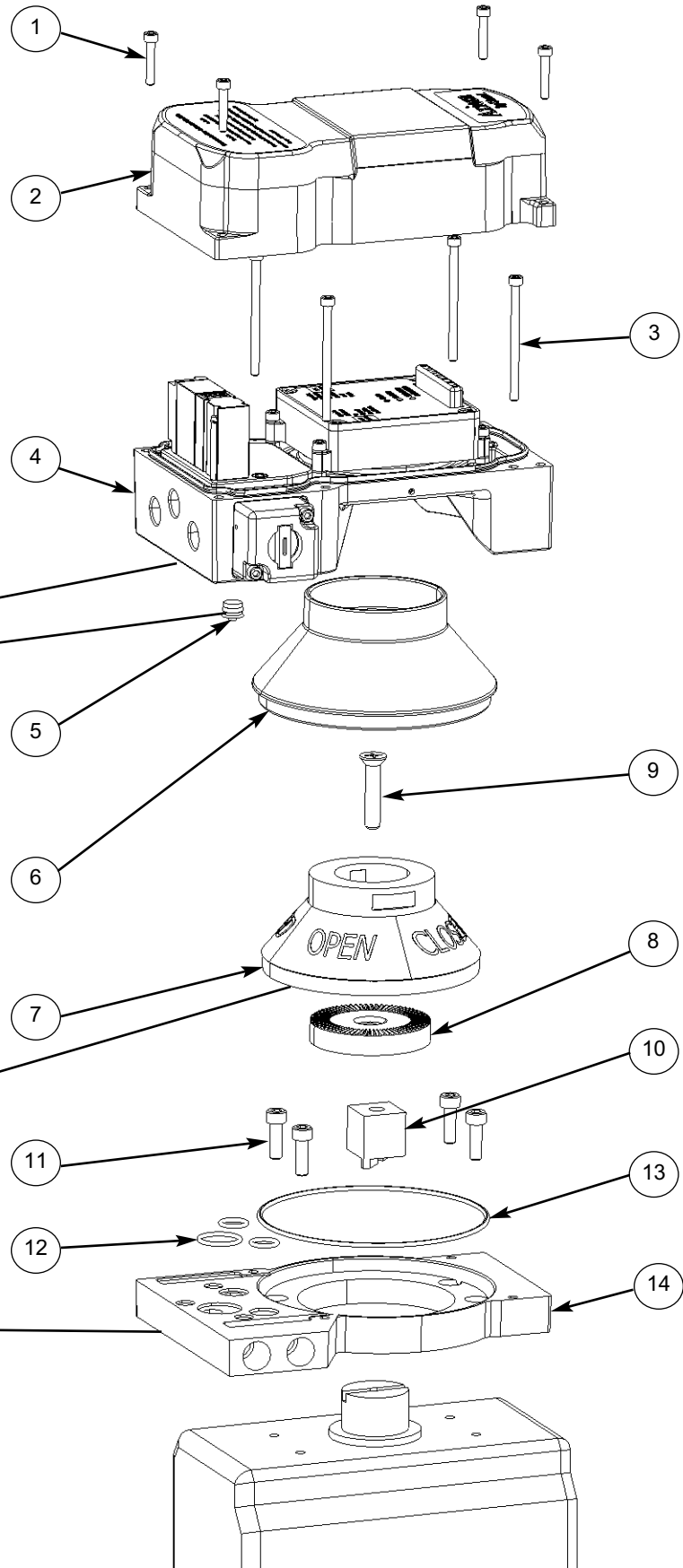

AMI97 _____ * models approved as Non-Incendive Field Wiring Apparatus:

* Any Conduit/Connector option and Visual Indicator option is approved.

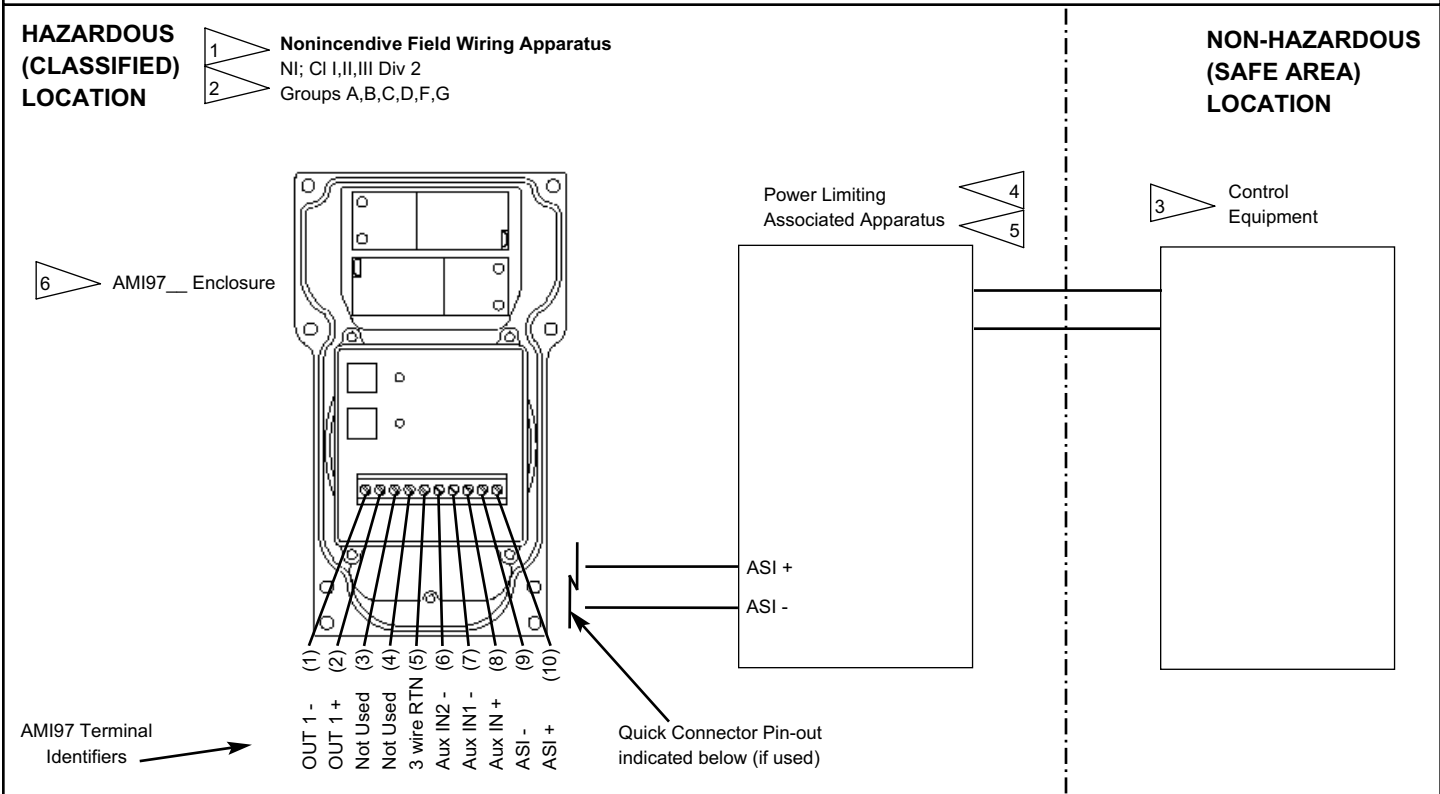

AMI97 Terminal Identifiers →

- (1) OUT 1 -
- (2) OUT 1 +
- (3) Not Used
- (4) Not Used
- (5) 3 wire RTN
- (6) Aux IN2 -
- (7) Aux IN1 -
- (8) Aux IN +
- (9) ASI -
- (10) ASI +

Quick Connector Pin-out indicated below (if used)

4-PIN MINI-CONNECTOR

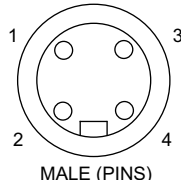

MALE (PINS)

PIN	SIGNAL
1	ASI+
2	Not Used
3	ASI-
4	Not Used

4-PIN MICRO-CONNECTOR

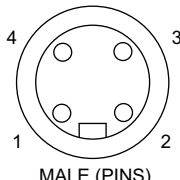

MALE (PINS)

PIN	SIGNAL
1	ASI+
2	Not Used
3	ASI-
4	Not Used

INSTALLATION NOTES:

Entity Parameters: AMI97 _____: $U_i = 37 \text{ Vdc}$; $I_i = 150 \text{ mA}$; $C_i = 0.0 \text{ nF}$; $L_i = 0.0 \text{ mH}$; $P_i = 3.0 \text{ W}$

1. Installation shall be in accordance with ANSI/ISA RPA12.6.01, ANSI/NFPA 70, and the National Electrical Code.
2. Dust-tight conduit seal must be used when installed in Class II and Class III environments or where Ingress Protection of IP67 is required.
3. Control equipment must be FM approved to supply power in Class I, Division 2 Areas.
4. Power Limiting Associated Apparatus must satisfy the conditions: $V_{oc} \text{ or } V_t \leq V_i$, $I_{sc} \text{ or } I_t \leq I_i$, $C_a \geq C_i + C_{cable}$, $L_a \geq L_i + L_{cable}$ of the AMI97 _____ Entity Parameters
5. Manufacturer's associated non-incendive field wiring apparatus installation drawing must be followed when installing this equipment.
6. Parts of the enclosure are non-conducting and may generate an ignition-capable level of electrostatic charge under certain extreme conditions. The user should ensure that the equipment is not installed in location where it may be subjected to external conditions (such as high-pressure steam) which might cause a build-up of electrostatic charge on non-conducting surfaces. Additionally, cleaning of the equipment should only be done with a damp cloth.
7. Substitution of components may impair hazardous location safety.